

installation manual

## INDUSTRIAL

hardware set for low  
headroom overhead  
doors (CE-LHR)

max. w = 5,0m  
max. h = 5,0m  
max. kg = 300kg  
CE-LHR, CE-FLH

©All rights reserved. Flexi-Force BV  
2006

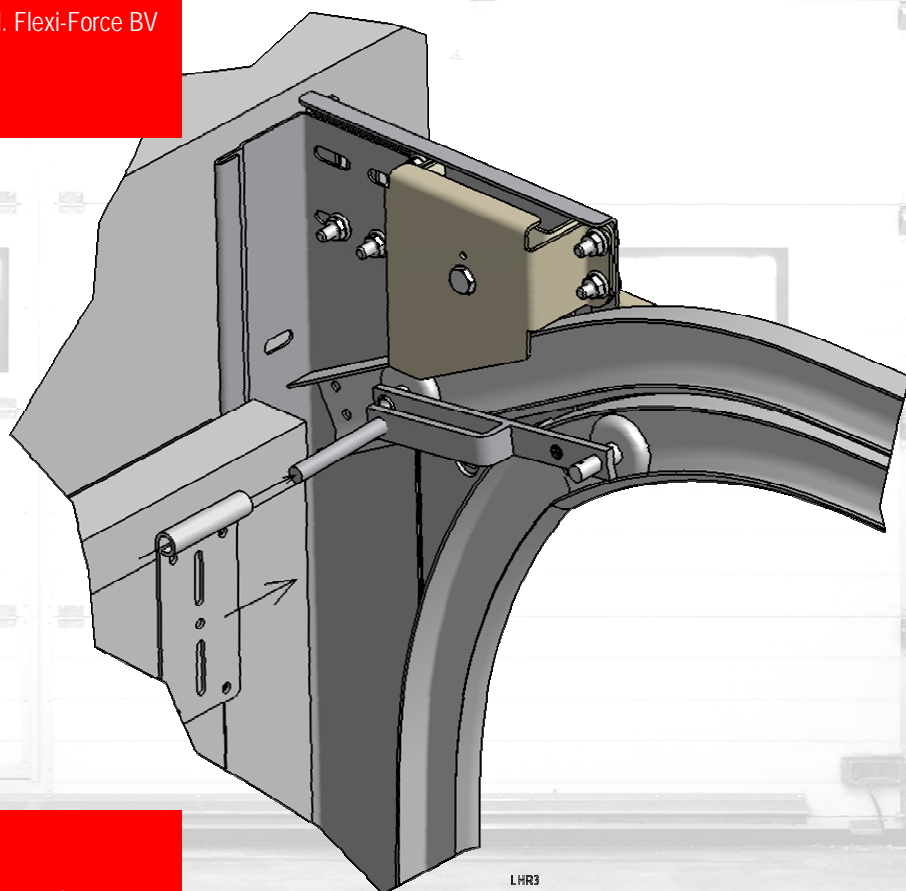



(patent pending)

GB

**ATTENTION! GENERAL WARNINGS!**

To install, use and maintain this door safely, a number of precautions must be taken. For the safety of all concerned pay heed to the warnings and instructions given below! If in doubt, contact your supplier.

- ✓ SPECIAL SAFETY WARNINGS OR REMARKS IN THIS MANUAL ARE INDICATED WITH THIS SYMBOL:  READ THESE WARNINGS CAREFULLY.
  - ✓ This manual has been written for use by experienced fitters and as such is not suitable for d.i.y. purposes or for use by trainee fitters.
  - ✓ This manual describes the installation of the hardware set components, door sections (panels) and refers to installation manuals of the electrical operators. Be sure to supplement this manual if needed with instructions for any additional components not described in this manual.
  - ✓ Before starting, read this manual carefully!
  - ✓ Certain components may be sharp or have jagged edges. As such you are advised to wear safety gloves.
  - ✓ All the components which have been supplied are designed for use with this specific overhead door. Replacement or adding additional components may have an adverse effect on the safety of, and the guarantee on, the door. Also the CE-approval which has been granted to this door combination will be cancelled when components are changed or installation is not done according to this manual! Installer is responsible for this.
  - ✓ During tensioning, springs can exert large forces. Work carefully. Use the proper equipment. Ensure that you are standing in a steady position.
  - ✓ Ensure that there is sufficient light during installation. Remove obstacles and dirt. Make sure that there is no one else present other than the fitters. Other people (children!) may get in the way or endanger themselves during the installation.
  - ✓ Ensure that the building is constructed strong enough to carry the overhead door construction. It is the responsibility of the installing company to use fixing materials which are strong enough and equipped to fix the overhead door to the building.
  - ✓ A power operated overhead door may not be equipped with a pull cord (rope). Be sure that this has been removed when a manual operated door is being equipped with an E-operator.
  - ✓ Environments closed by an electrical operated overhead door with operators which are not disconnectable and where the door cannot be manual operated must be equipped with a pass door.
  - ✓ Cutting of the bottom section is not allowed. The forces on cable break devices and bottom brackets are too high. Cutting is weakening the construction of the door on this critical point. If you need to cut the bottom section make sure you can guarantee the strength.
- This door can only be taken into use, when all instructions are followed and:
-  ✓ the installer has checked the combination of hardware, panel and e-operator as being approved and safe. Make sure to check the max. peak force and the proper functioning of the safety edge system in combination with the operator.
  - ✓ all documentation has been handed over to the end-user: Ila Declaration of conformity, User Guide, Maintenance Instructions, Dismantling instructions, Service Log Book and this manual.
  - ✓ a CE-identification plate has been placed on the door.
  - ✓ user has been given instructions and demonstration of the proper use and functioning of the door.

## GUARANTEE, CONDITIONS AND TERMS

The general terms and conditions of delivery and payment issued by the Metaalunie and designated as METAALUNIE CONDITIONS are fully applicable to all our quotations, contracts and their implementation. We expressly reject all other terms and conditions. On request we will send you a copy of these terms and conditions free of charge. A copy may also be downloaded from our website [www.flexiforce.nl](http://www.flexiforce.nl).

Flexi-Force strives to deliver 100 % in conformance with the order. In practice, in spite of all our controls, this is not always possible. However we will rectify any errors as quickly as possible, in order to minimise the inconvenience caused to you or the user. As such, it is important that you inform us as soon as possible about any problem with the delivery (include the order number and week of production) and give us the opportunity to offer a suitable solution.

Flexi-Force will only reimburse third party costs if we have given explicit permission for this in advance. The reimbursement is based on normal rates and travelling expenses over distances of 1 hour away at most.

For large-scale projects we strongly advise you to first install 1 door completely before installing the other doors. In this way, any errors can be detected early on and rectified comparatively cheaply.

This manual does not confer any rights. Technical modifications may be made without written notice.

Flexi-Force has endeavoured to design and put together this hardware set in conformance with the applicable CE-norms. However, we recommend to check our configuration against any local national specification.

Flexi-Force B.V., P.O. Box 37, 3770 AA Barneveld, The Netherlands  
Tel. +31-(0)342-427777, [ff@flexiforce.nl](mailto:ff@flexiforce.nl)

## APPLICABLE CE DIRECTIVES AND RESTRICTIONS:

Industrial overhead doors brought into the European market must follow the EMC-Directive\*, Low Voltage Directive\*, Machine Directive\* and Construction Products Directive, issued by CEN.

(\* = only power-operated doors)

Flexi-Force has developed and constructed this hardware set according to these directives. This gives a restriction to the max. forces and dimensions of industrial doors:

- Max width : 5 meter
- Max height : 5 meter
- Max door weight : 300 kg
- Standard equipped with anti-drop protection: Cable break device and spring breaking device
- Other safety accessories: roller protection, bottom safety edge system (when power operated), slack cable device, cable inside track system.
- Tested for CE when selecting the proper Flexi-Force components, and combining with tested panels and operator/control unit combinations.
- Use of finger safe sections for door heights <2,75m.
- Cables outside the track system are not allowed, unless the cables are covered.



Flexi-Force has applied the mandated INITIAL TYPE TESTING for doors described in this manual, at the SP-Institute in Sweden (as Notified Body Nr. 0402). The INITIAL TYPE TESTING REPORT that has been rewarded, can be transferred to the door producing company when truly declared conformity is done. This is needed to complete your CE technical construction file according to product standard EN13241-1. The ITTR-number should be placed on the CE-plate on the door.

The article codes of the parts are given in (parentheses). This door can only be installed according to the CE-certificate if all parts are according to the parts lists of the SP-certificate. See [www.flexiforce.com](http://www.flexiforce.com).

This manual should be completed with additional installation manuals for IND Hardware sets, cable break devices, spring break devices and E-operator.

## SYSTEM DESCRIPTION

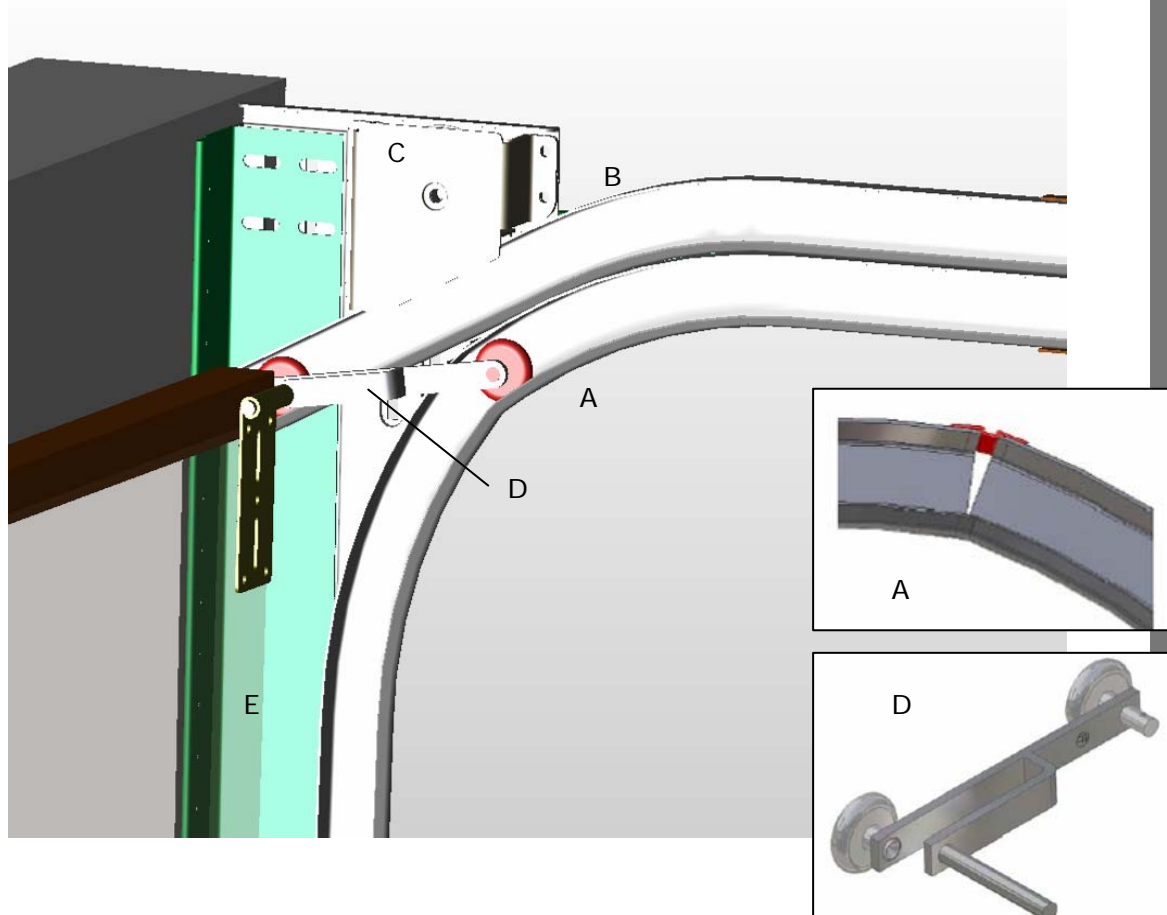

The system is really simple. First of all the needed head room: minimal 205mm!

To achieve this we have designed a special curve assembly, 567-554-2GD. It contains a special lower curve (A), with a "double radius". This curve is cut and welded resulting in a "sharper" curve. The upper curve (B) runs just under the cable pulley system (C). This system consists of a cable pulley mounted and secured to the side plate through a top pulley plate. This part of the system is supplied to you completely pre-assembled.

The cable runs through the new designed, fork-shaped roller (D), article code 593, through the track and is finally connected to the cable break device, article code 440-LHR. To create the space needed for the cable, a different type of vertical angle is used, code 9K...(E). The distance between panel and track is bigger compared to other lift systems. Therefore the rollers need to have a longer shaft as well, article code 575LHR and 575-304LHR (stainless steel).

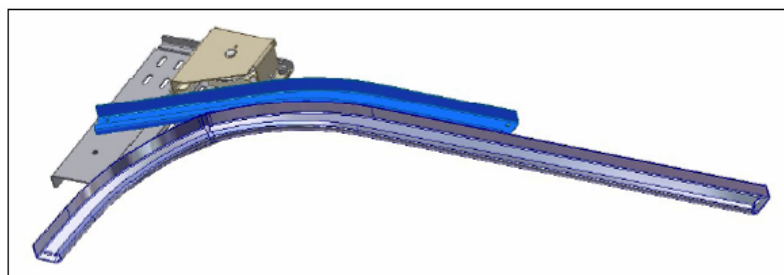

567-554-2GD

Available lift systems:

- LHR = Low Head Room
- FLH = Following the roof Low Head room (CE-FLH) with angles in steps of 5 degrees (max 28°).

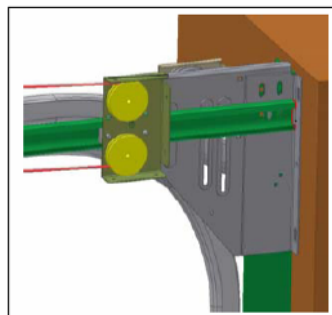
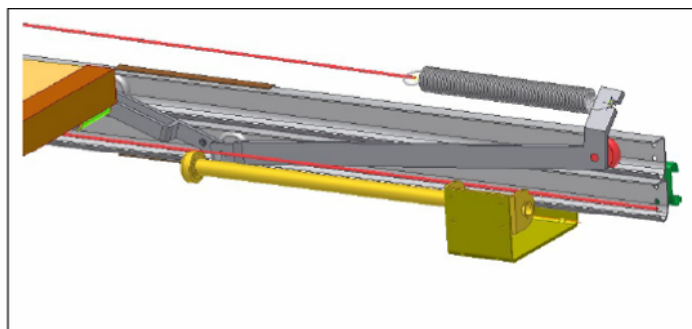

688CR

A special tension set has been designed for combining with this new system. Article code 688CR/L. See attached build-in instructions.

## BUILD-IN SPECIFICATIONS

Minimum build in height 40 mm panel.	no 6" springs	6" springs
	FF-NL-12, FF-NL-18 no tension set 688CR	<b>205 mm</b>
with tension set 688CR	<b>230 mm</b>	<b>230 mm</b>
FF-NL-32	<b>240 mm</b>	<b>240 mm</b>

The system is suitable for panel thickness between 40 and 50 mm. For thicker panels than 40 mm the build in height will increase.

Needed side room	
no tension set 688CR	<b>120 mm</b>
with tension set 688CR	<b>145 mm</b>

## INSTALLATION OF TRACK SYSTEM

### Distinguishing feature

With CE-LHR systems the door turns through the bend directly above the clear height. The horizontal section consists of a double track. See figure.

### Tracks

The track system of the LHR System consists of a vertical and a horizontal section.

### Vertical track set

This is made up of a left-hand and right-hand assembled vertical angles (9K) with track and side seal.

### Horizontal track set

The horizontal track set consists of a left-hand and right-hand section with a double bend, straight tracks and a reinforcement profile. The bends and the straight guide tracks are fitted to each other by connection plates and a side plate. The side plate is fitted with a return pulley system. The side plate is supplied pre-assembled.

### **Assembly vertical track set**

Slide the side seal onto the corner line and shorten this where necessary. Secure the vertical track set level to the pendent.

Ensure that the side seal cannot be displaced. When necessary deform the rim of the corner line above the side seal.

### **Assembly horizontal track set**

Secure a piece of rope to the ceiling or roof structure. Adjust the horizontal track. Tighten all bolts.

Other instructions can be found in the general Installation Manual of our industrial hardware sets.



**WARNING: IN CASE OF INSTALLING THE HORIZONTAL TRACK SET ON HORIZONTAL LEVEL A 688CR CABLE TENSION SET MUST BE INSTALLED TO PREVENT SLACK CABLES. ONLY WHEN THE SHAFT IS DIRECTLY ACTIVATED (CHAIN HOIST OR OPERATOR).**

### **OTHER REMARKS**

- On doors with small heights locks must be installed at height less than 700 mm. Otherwise the lock bar will hit the cable.
- Shape of bottom rubber must be so that it does not hit the side seal when opening the door.
- Length of horizontal track on LHR is standard based on mounting a tension set even if it is not part of the delivery.
- When ordered "double hardware" the standard top roller construction for single hardware is supplied.

### **LIST OF PRODUCTS SPECIAL FOR CE-LHR**

<u>Article code</u>	<u>Description</u>
567-554-2GD	Side plate curve assembly LHR
567-554-2GD-05/28	Side plate curve assembly FLH 5° / .../28°
593	Top roller
575LHR	Roller
575-304LHR	Roller, stainless steel
440LHR	Cable break device LHR
9K4500	Vertical angle
9K6500	Vertical angle
688CR	Tension set LHR right
2090L	Bracket for spring bumper
632L	Slide bolt with longer rod
669S	Cylinder lock

## INSTALLATION STEP BY STEP

1

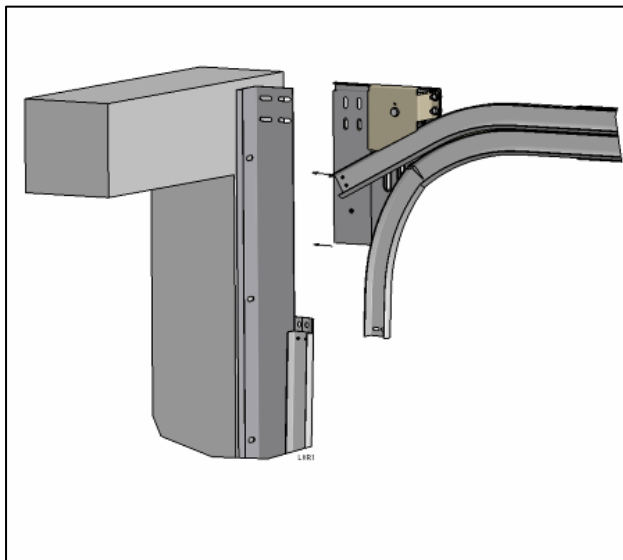

2

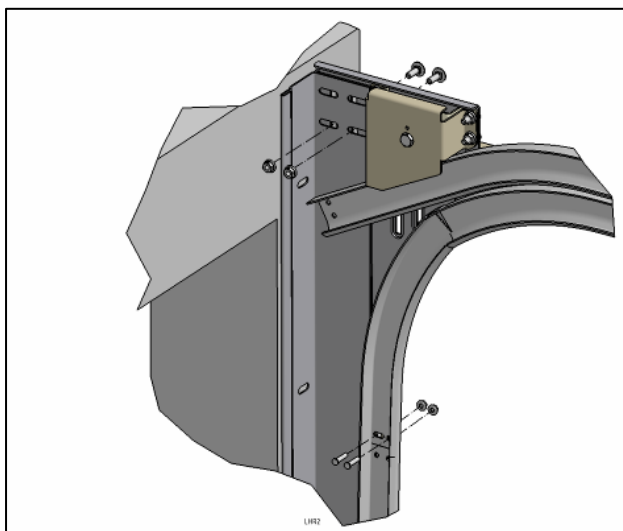

3

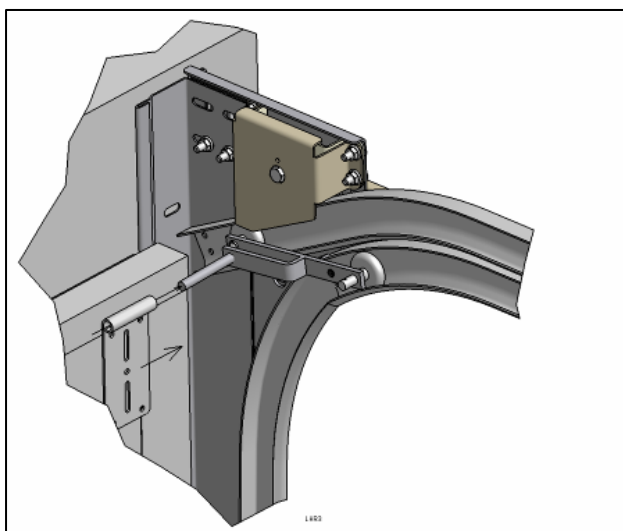

4

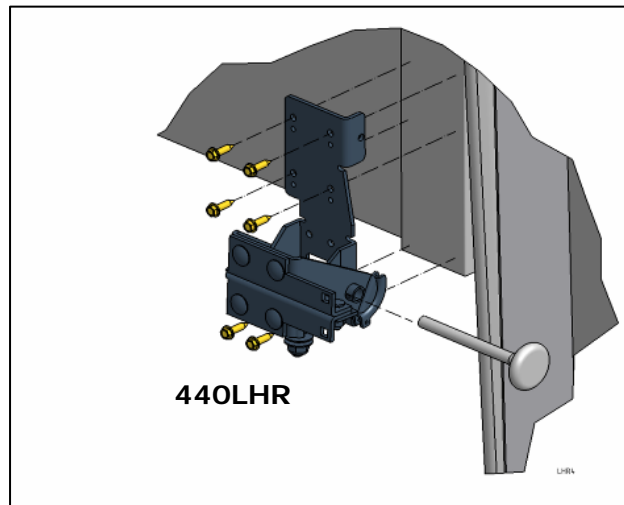

5

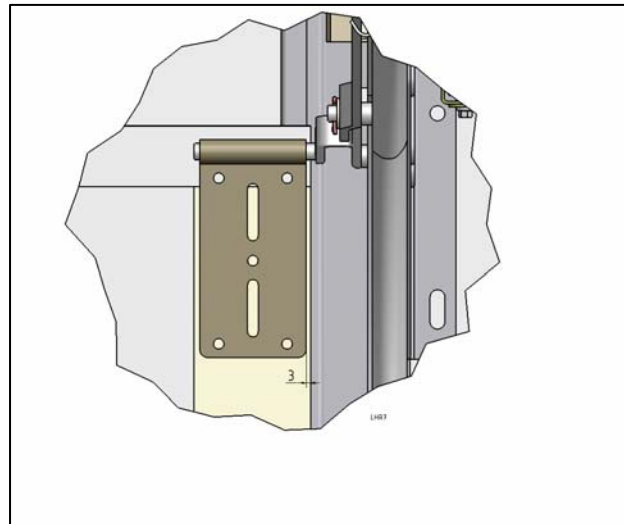

6

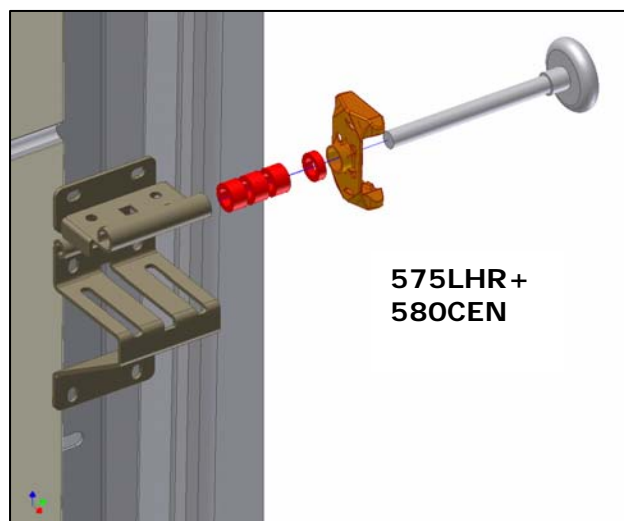

Roller of upper adjustable hinge must be filled out with bushes to protect the top tandem roller.



7

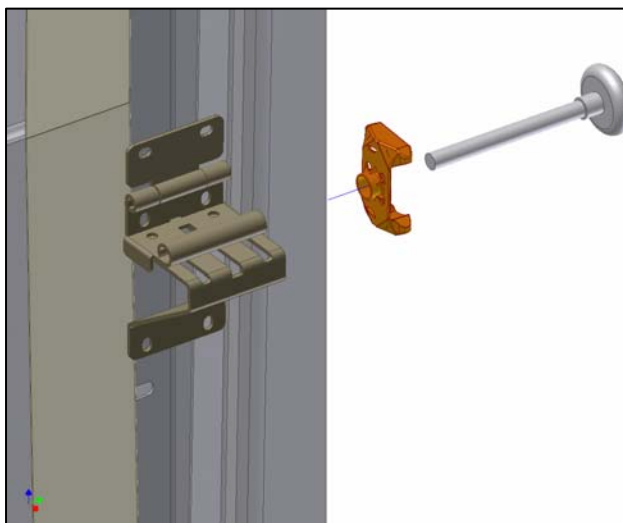

8

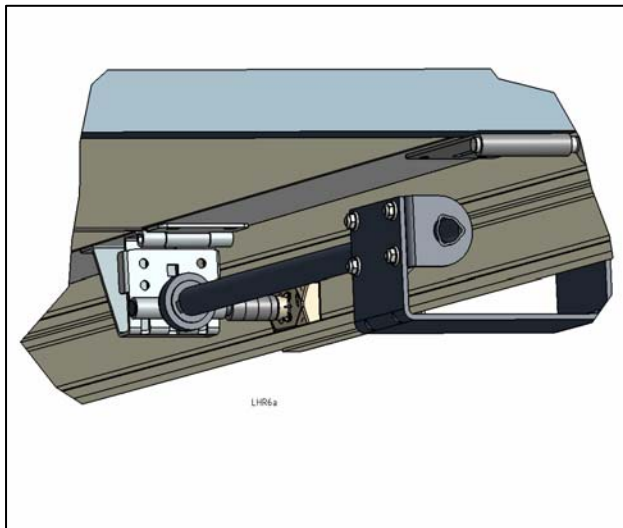
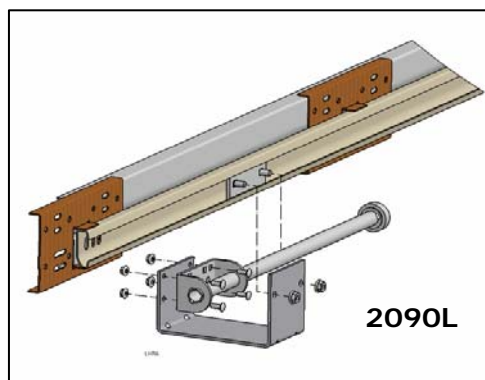

9

688CR INSTALLATION

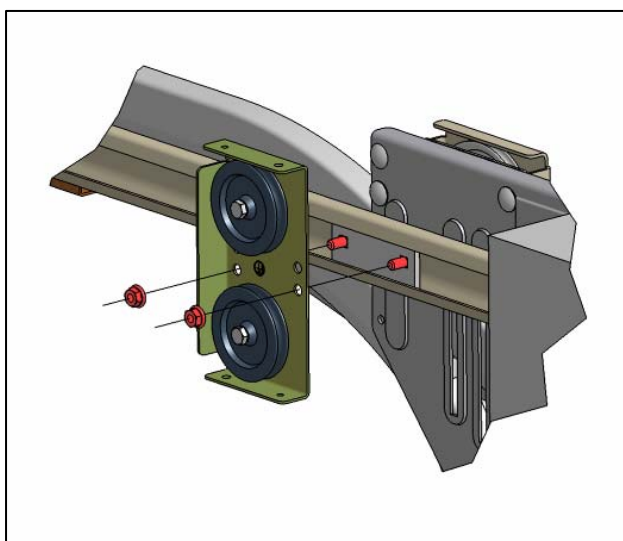

10

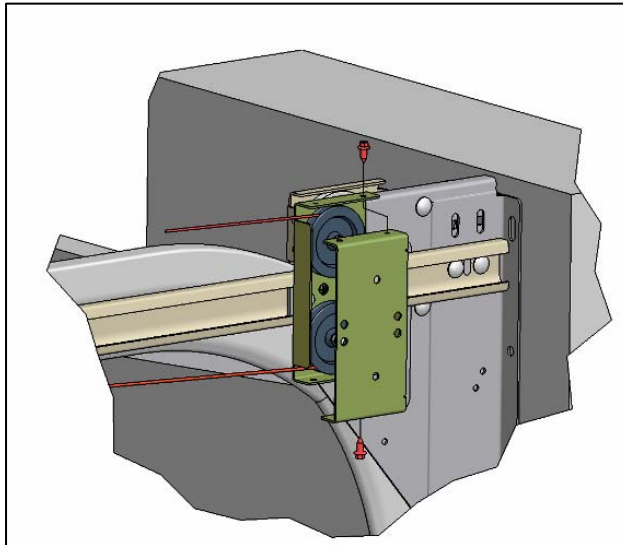

11

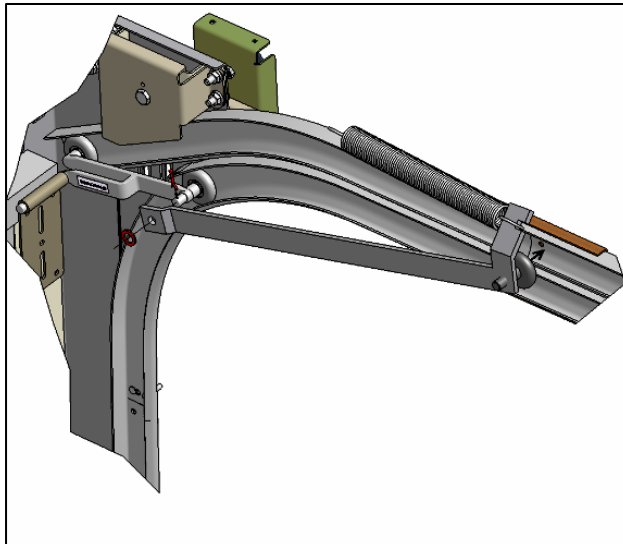

12

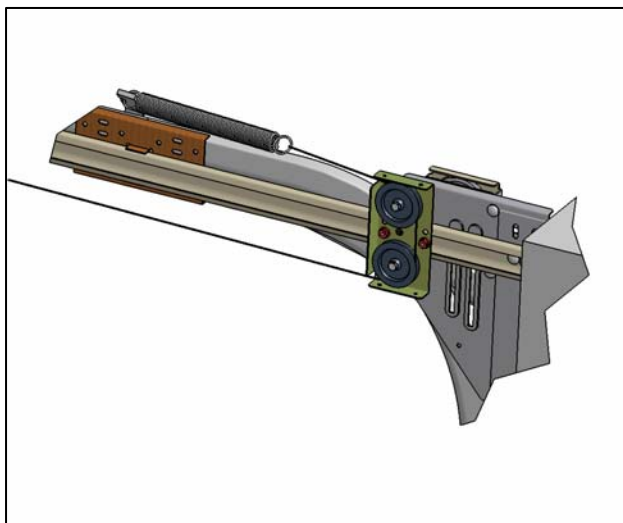

## DETAILS

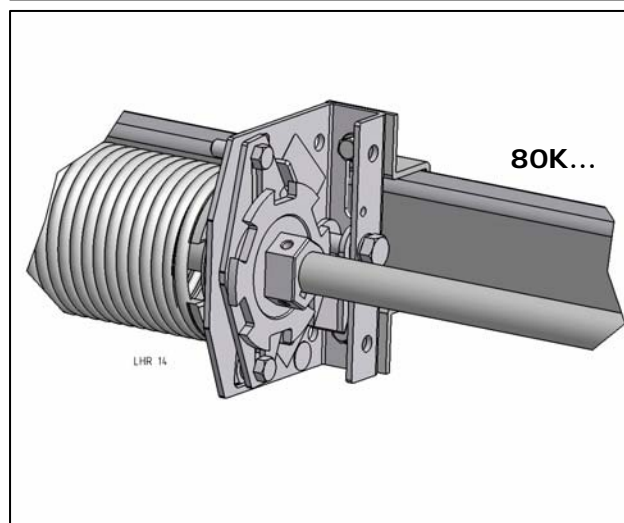
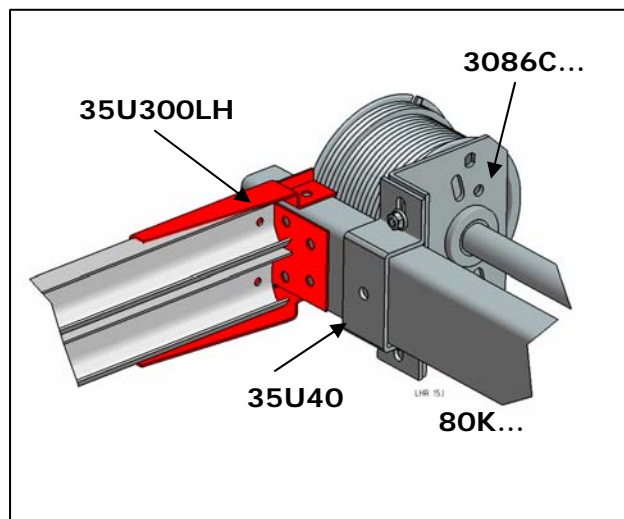
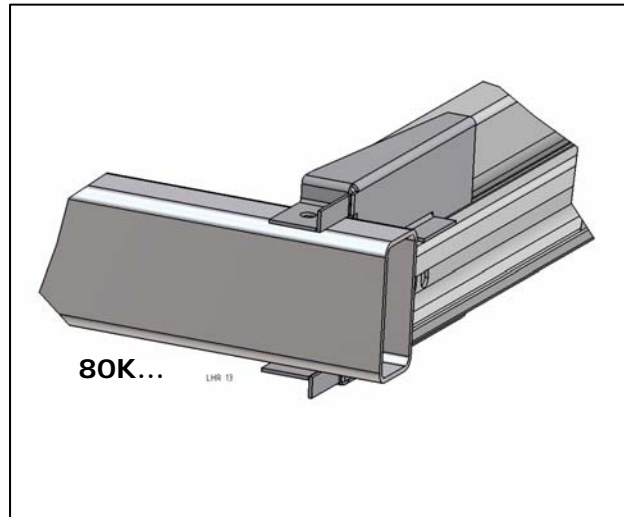

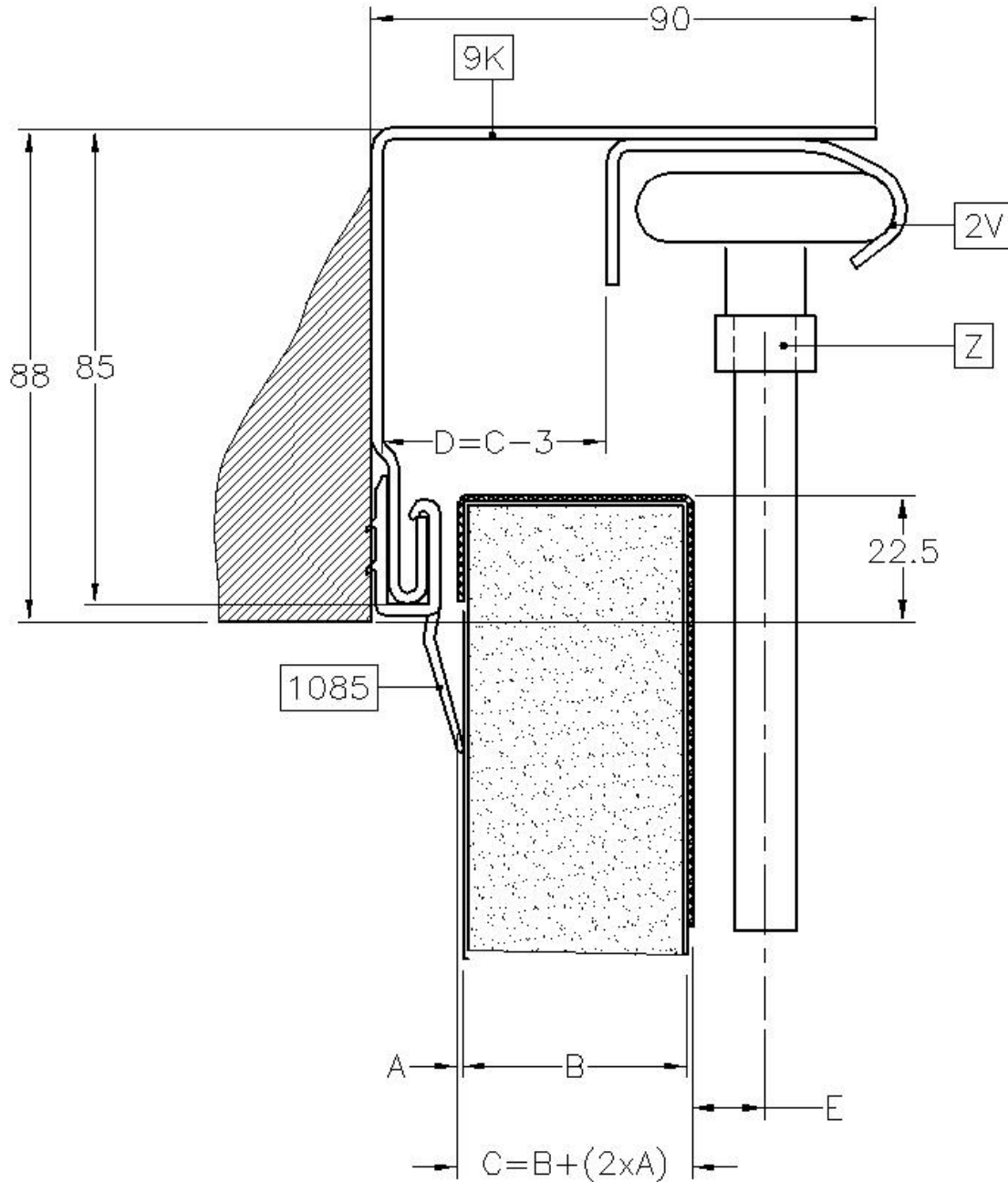

TYPE	X	Z	E
440LHR	88	-	13

If, wenn, si

B= 40 mm  
 A= 1 mm  
 $C=40+(2 \times 1)=42$  mm  
 $D=42-3=39$  mm

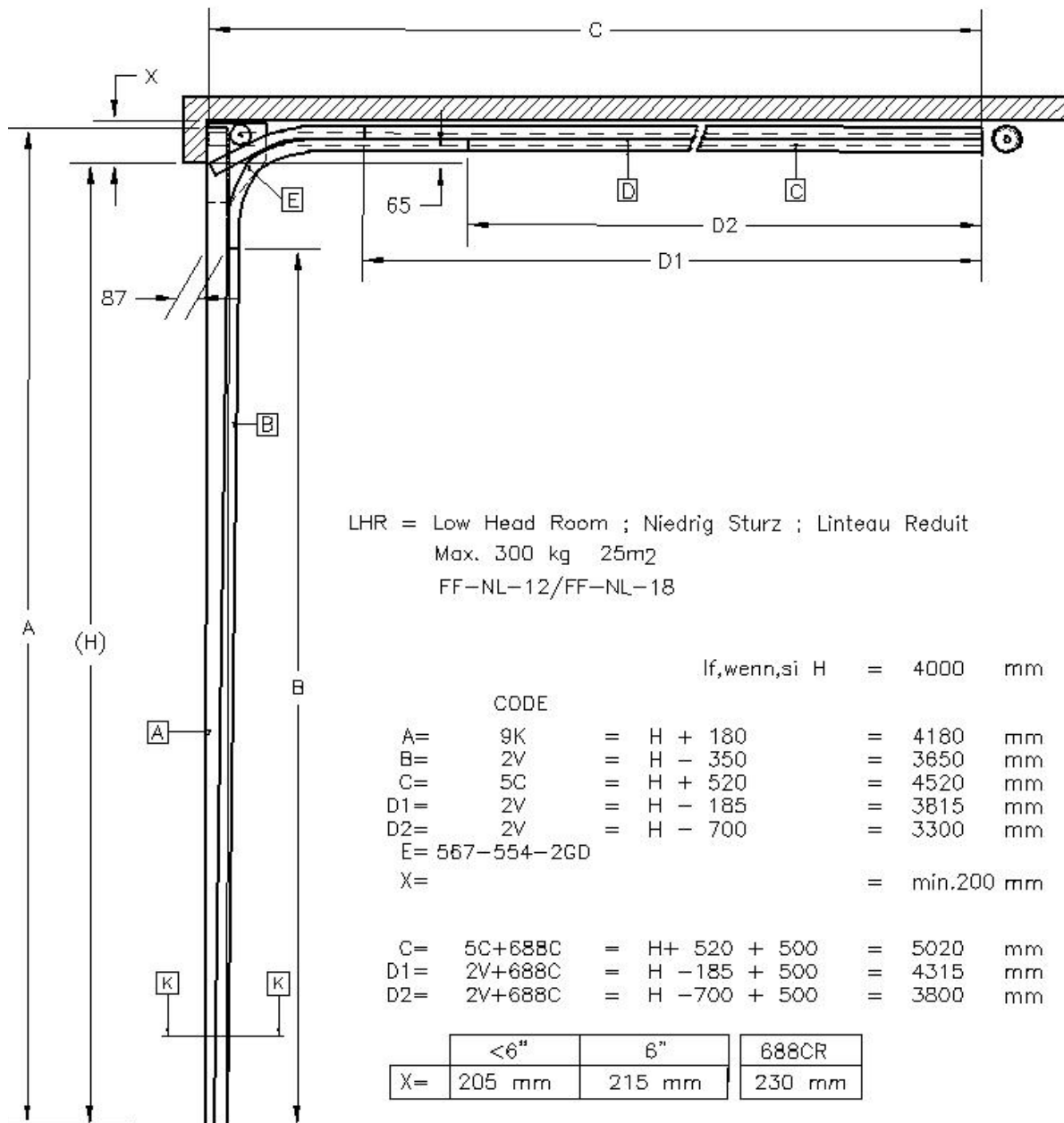

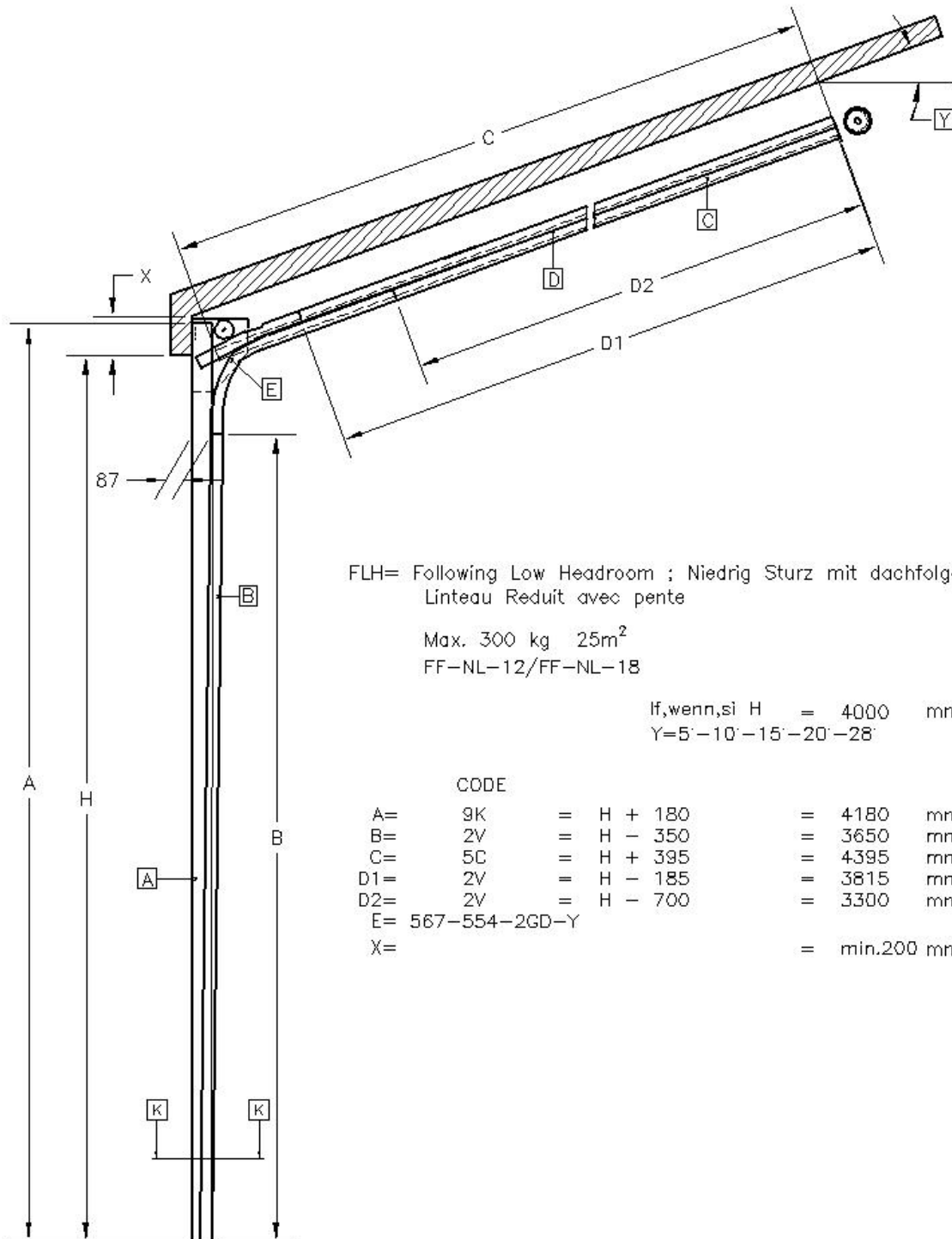

FLH= Following Low Headroom ; Niedrig Sturz mit dachfolge;  
 Linteau Réduit avec pente

Max. 300 kg 25m<sup>2</sup>  
 FF-NL-12/FF-NL-18

If, wenn, si H = 4000 mm  
 Y=5°-10°-15°-20°-28°

CODE

A=	9K	=	H + 180	=	4180	mm
B=	2V	=	H - 350	=	3650	mm
C=	5C	=	H + 395	=	4395	mm
D1=	2V	=	H - 185	=	3815	mm
D2=	2V	=	H - 700	=	3300	mm
E=	567-554-2GD-Y					
X=						= min.200 mm