



**manual**

Industrial Hardware Manual

# ISC-HL



## INDUSTRIAL HARDWARE SET FOR OVERHEAD DOORS

Installation Manual



## ATTENTION! GENERAL WARNINGS!



To install, use and maintain this door safely, a number of precautions must be taken. For the safety of all concerned pay heed to the warnings and instructions given below! If in doubt, contact your supplier.



**SPECIAL SAFETY WARNINGS OR REMARKS IN THIS MANUAL ARE INDICATED WITH THIS SYMBOL: READ THESE WARNINGS CAREFULLY.**

- ✓ This manual has been written for use by experienced fitters and as such is not suitable for d.i.y. purposes or for use by trainee fitters.
- ✓ This manual describes the installation of the hardware set components, door sections (panels) and refers to installation manuals of the electrical operators. Be sure to supplement this manual if needed with instructions for any additional components not described in this manual.
- ✓ Before starting, read this manual carefully!
- ✓ Certain components may be sharp or have jagged edges. As such you are advised to wear safety gloves.
- ✓ All the components which have been supplied are designed for use with this specific overhead door. Replacement or adding additional components may have an adverse effect on the safety of, and the guarantee on, the door. Also the CE-approval which has been granted to this door combination will be cancelled when components are changed or installation is not done according to this manual! Installer is responsible for this.
- ✓ During tensioning, springs can exert large forces. Work carefully. Use the proper equipment. Ensure that you are standing in a steady position.
- ✓ Ensure that there is sufficient light during installation. Remove obstacles and dirt. Make sure that there is no one else present other than the fitters. Other people (children!) may get in the way or endanger themselves during the installation.
- ✓ Ensure that the building is constructed strong enough to carry the overhead door construction. It is the responsibility of the installing company to use fixing materials which are strong enough and equipped to fix the overhead door to the building.
- ✓ A power operated overhead door may not be equipped with a pull cord (rope). Be sure that this has been removed when a manual operated door is being equipped with an E-operator.
- ✓ Environments closed by an electrical operated overhead door with operators which are not disconnectable and where the door cannot be manual operated must be equipped with a pass door.
- ✓ Cutting of the bottom section is not allowed. The forces on cable break devices and bottom brackets are too high. Cutting is weakening the construction of the door on this critical point.

### **This door can only be taken into use, when all instructions are followed and:**

- ✓ The installer has checked the combination of hardware, panel and e-operator as being approved and safe. Make sure to check the max. peak force and the proper functioning of the safety edge system in combination with the operator.
- ✓ All documentation has been handed over to the end-user: Ila Declaration of conformity, User Guide, Maintenance Instructions, Dismantling instructions, Service Log Book and this manual.
- ✓ A CE-identification plate has been placed on the door.
- ✓ User has been given instructions and demonstration of the proper use and functioning of the door.

## GUARANTEE, CONDITIONS AND TERMS

The general terms and conditions of delivery and payment issued by the Metaalunie and designated as METAALUNIE CONDITIONS are fully applicable to all our quotations, contracts and their implementation. We expressly reject all other terms and conditions. On request we will send you a copy of these terms and conditions free of charge. A copy may also be downloaded from our website [www.flexiforce.com](http://www.flexiforce.com). Flexi-Force strives to deliver 100 % in conformance with the order. In practice, in spite of all our controls, this is not always possible. However we will rectify any errors as quickly as possible, in order to minimise the inconvenience caused to you or the user. As such, it is important that you inform us as soon as possible about any problem with the delivery (include the order number and week of production) and give us the opportunity to offer a suitable solution.

Flexi-Force will only reimburse third party costs if we have given explicit permission for this in advance. The reimbursement is based on normal rates and travelling expenses over distances of 1 hour away at most.

For large-scale projects we strongly advise you to first install 1 door completely before installing the other doors. In this way, any errors can be detected early on and rectified comparatively cheaply.

This manual does not confer any rights. Technical modifications may be made without written notice.

Flexi-Force has endeavoured to design and put together this hardware set in conformance with the applicable CE-norms. However, we recommend to check our configuration against any local national specification.

Flexi-Force B.V., P.O. Box 37, 3770 AA Barneveld, The Netherlands

Tel. +31-(0)342-427777, [info.nl@flexiforce.com](mailto:info.nl@flexiforce.com)

## APPLICABLE CE DIRECTIVES AND RESTRICTIONS:

Industrial overhead doors brought into the European market must follow the EMC-Directive\*, Low Voltage Directive\*, Machine Directive\* and Construction Products Directive, issued by CEN.

(\* = only power-operated doors)

Flexi-Force has developed and constructed this hardware set according to these directives. This gives a restriction to the max. forces and dimensions of industrial doors:

- Max width : 8 meter
- Max height : 6 meter
- Max door weight : 700 kg
- Standard equipped with anti-drop protection: Cable break device and spring breaking device
- Other safety accessories: roller protection, bottom safety edge system (when power operated), slack cable device, cable inside track system.
- Tested for CE when selecting the proper Flexi-Force components, and combining with tested panels and operator/control unit combinations.
- Use of finger safe sections for door heights <2,75m.
- Cables outside the track system are not allowed, unless the cables are covered.



FlexiForce has applied the mandated INITIAL TYPE TESTING for doors described in this manual, at the SP-Institute in Sweden (as Notified Body Nr. 0402). The INITIAL TYPE TESTING REPORT that has been rewarded, can be transferred to the door producing company when truly declared conformity is done. This is needed to complete your CE technical construction file according to product standard EN13241-1. The ITTR-number should be placed on the CE-plate on the door.

The article codes of the parts are given in (parentheses). This door can only be installed according to the CE-certificate if all parts are according to the parts lists of the SP-certificate. See [www.flexiforce.com](http://www.flexiforce.com).

# FF Installation manual

## INDUSTRY

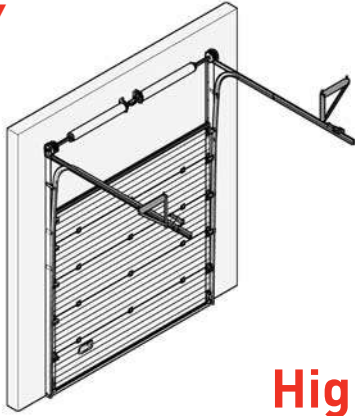

**High lift**

108A-1

01 108 991 rev. 13-04-2015

1

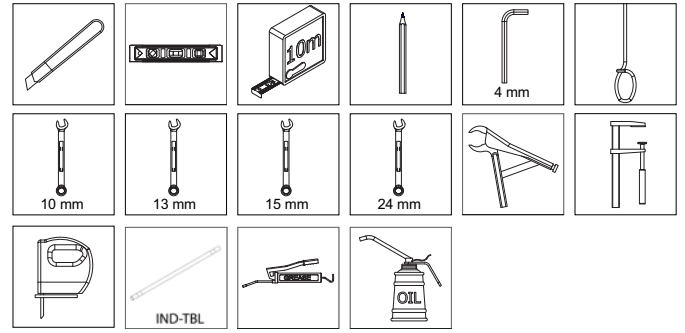

01 108 991 rev. 13-04-2015

2

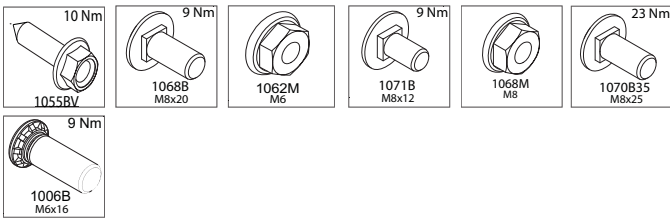

01 108 991 rev. 13-04-2015

3

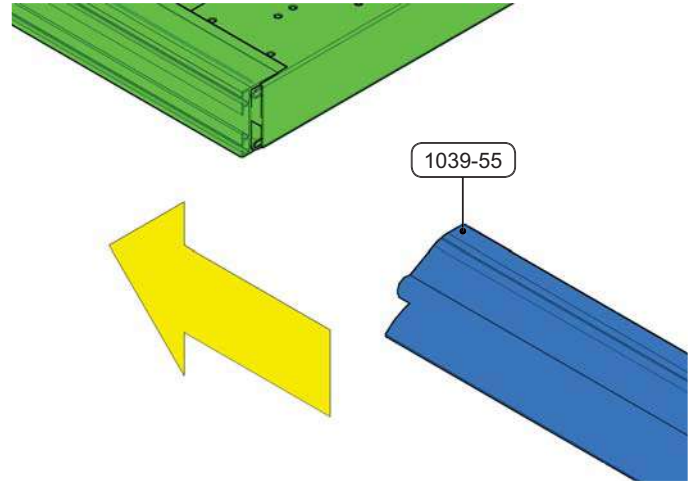

106B1-7

01 108 991 rev. 13-04-2015

4

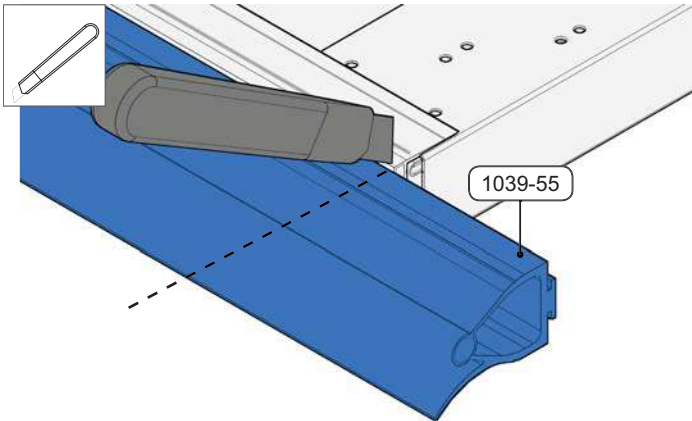

106B1-8

01 108 991 rev. 13-04-2015

5

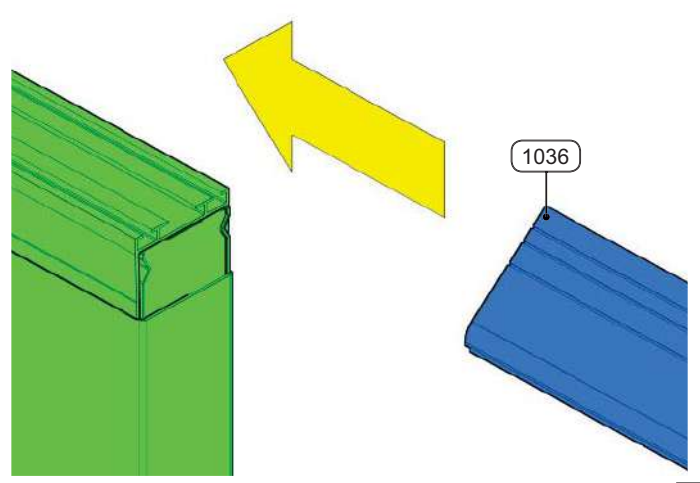

106C1-1

01 108 991 rev. 13-04-2015

6

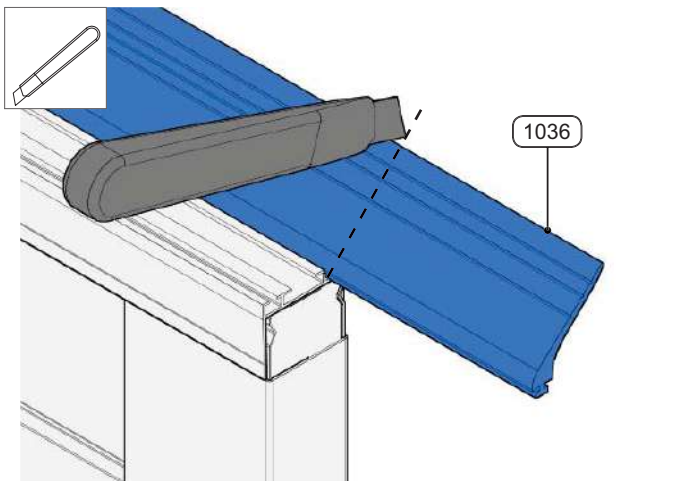

106C1-2

01 108 991 rev. 13-04-2015

7

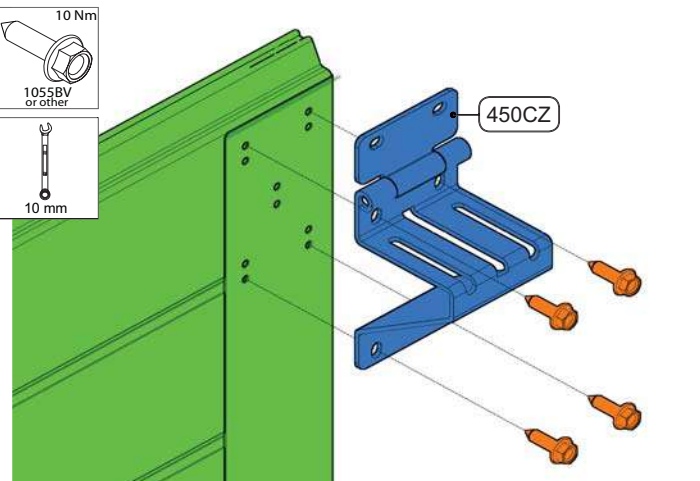

106I1-1

01 108 991 rev. 13-04-2015

8

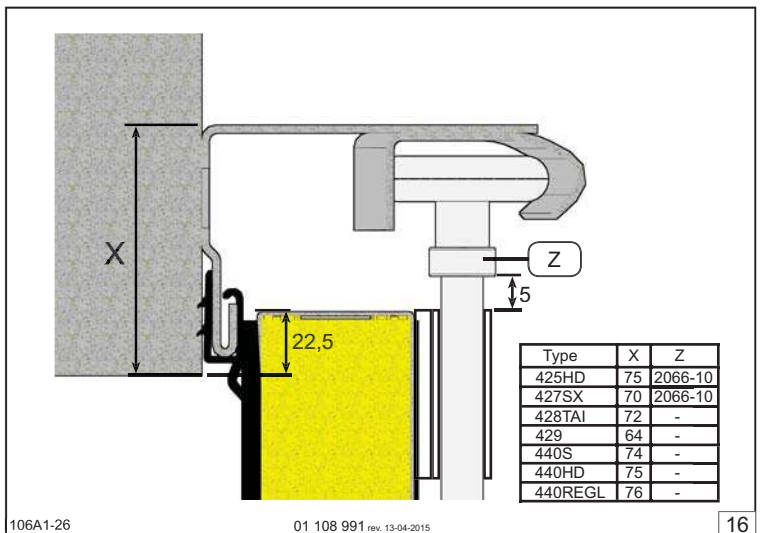
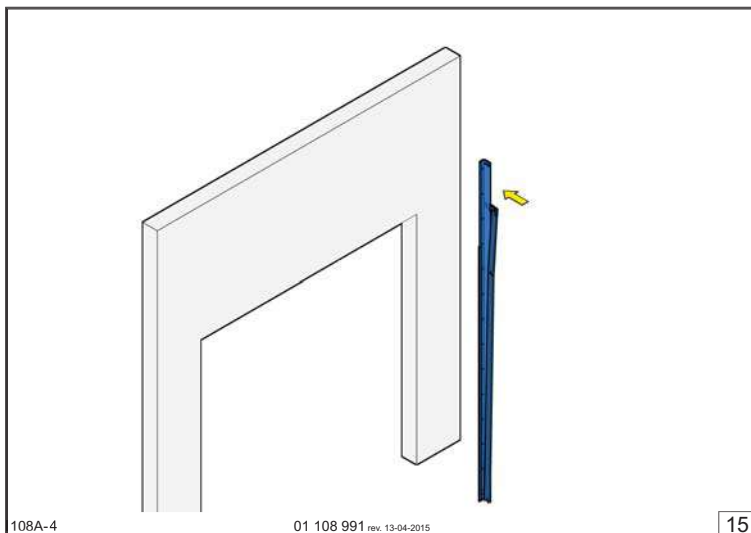
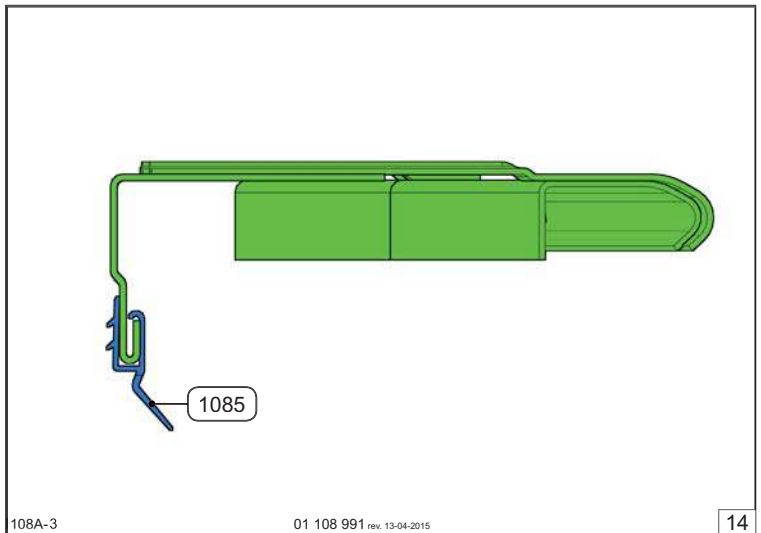
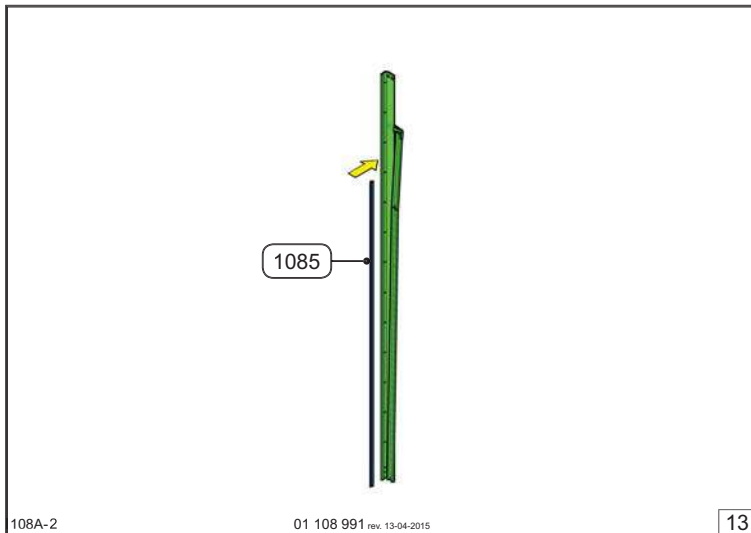
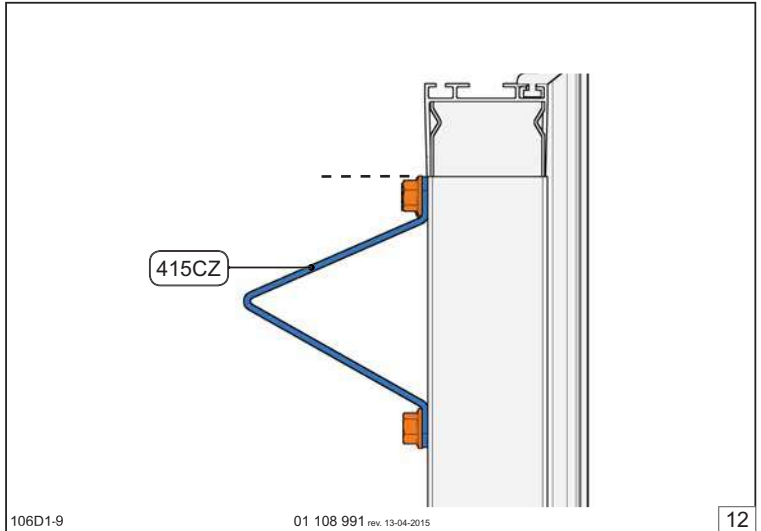
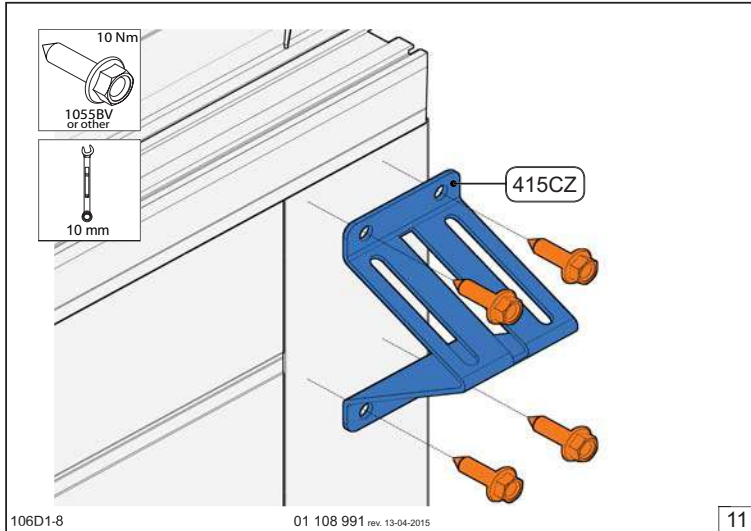
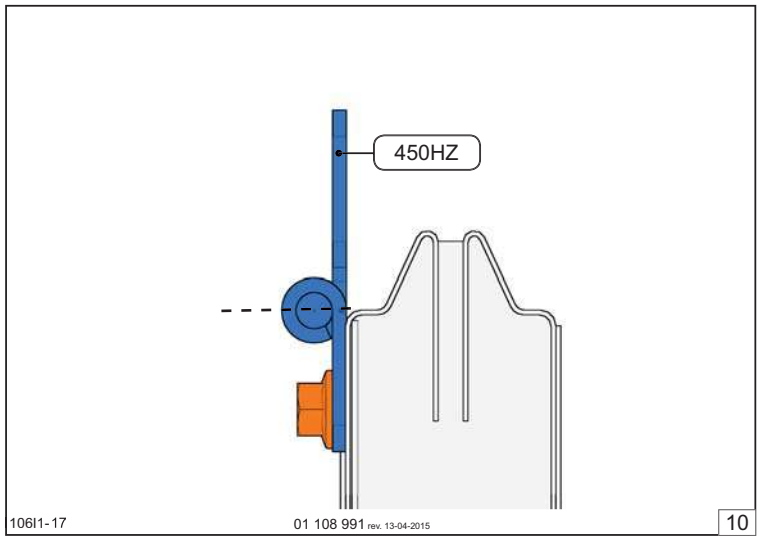
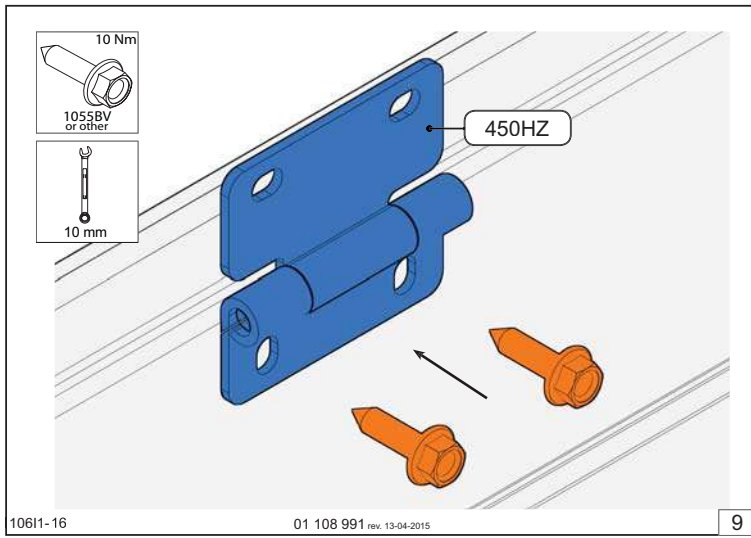



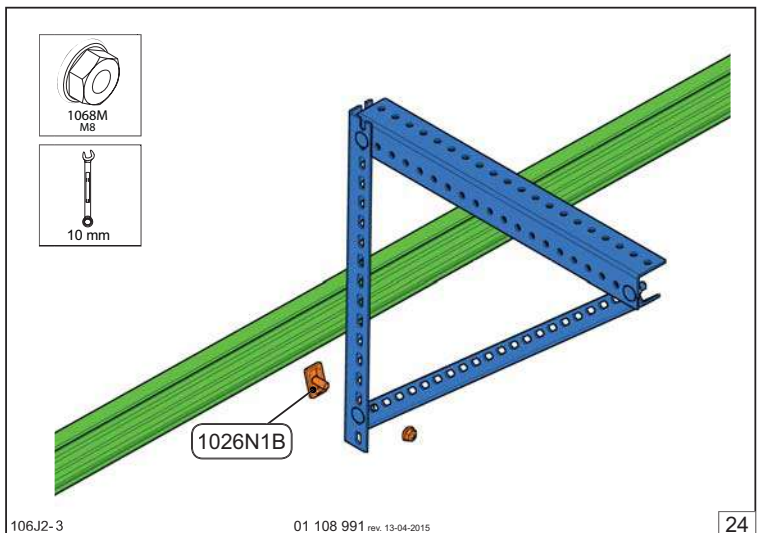
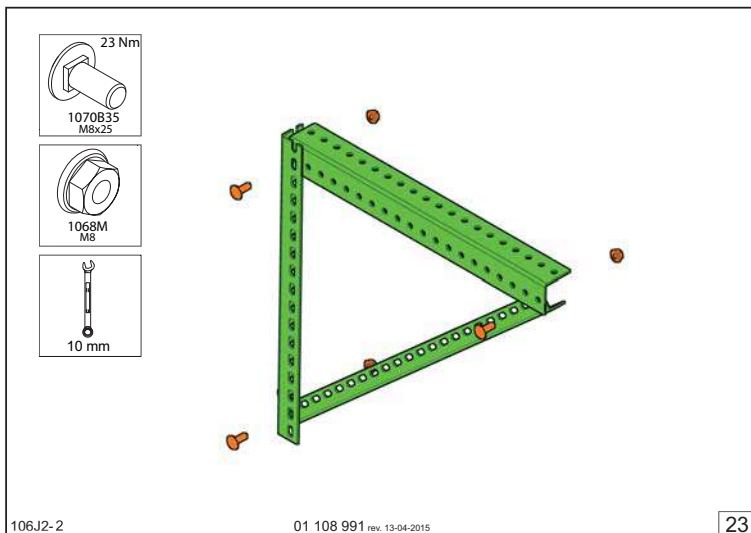
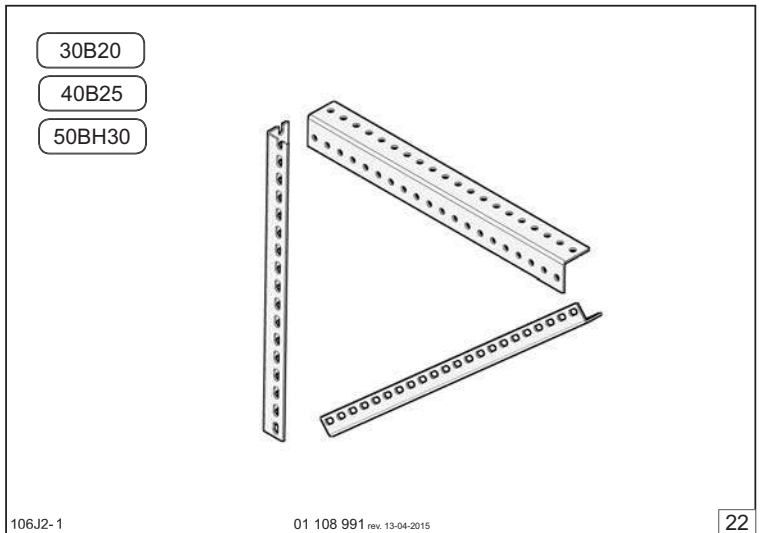
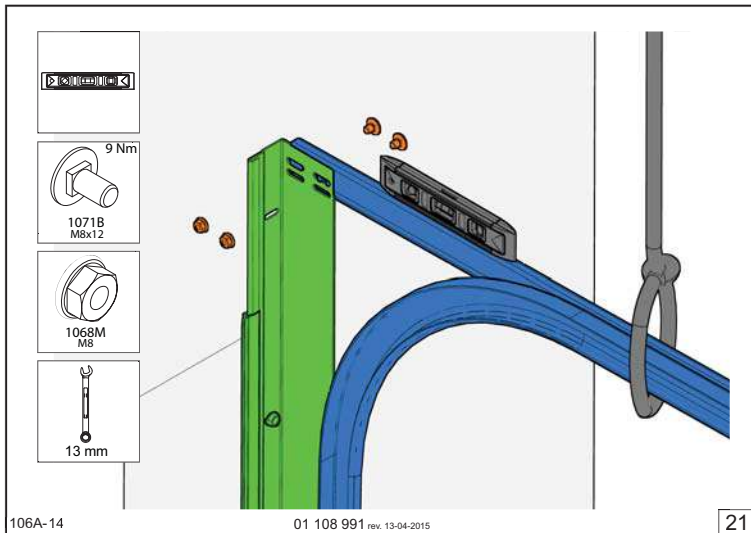
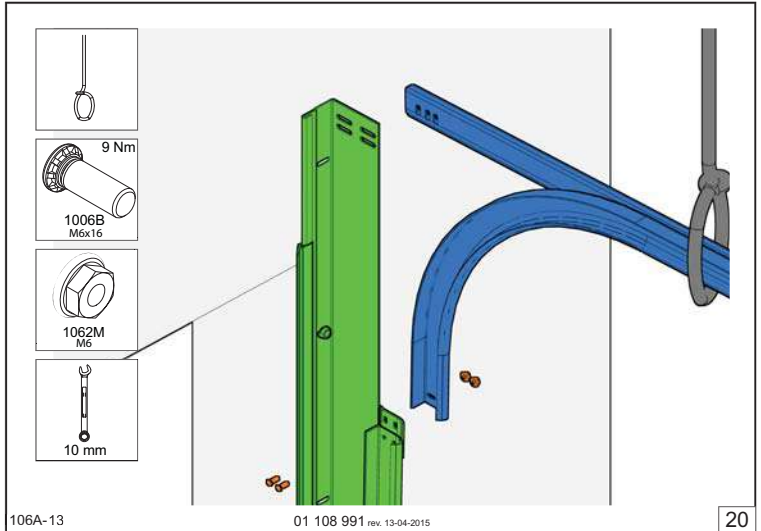
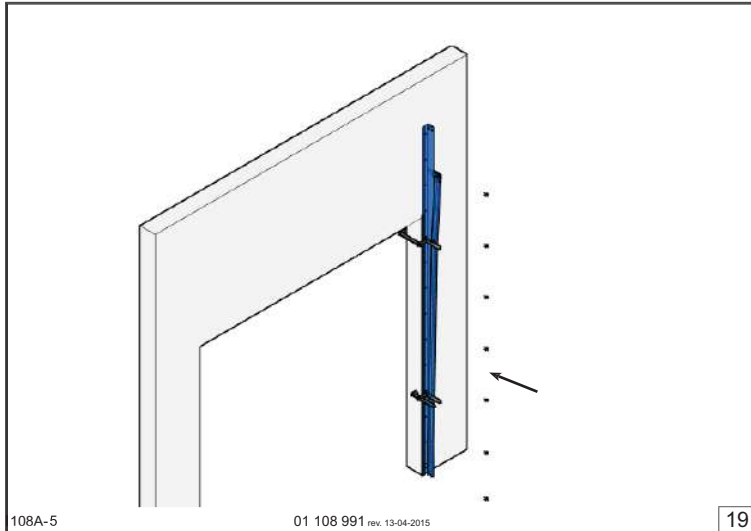
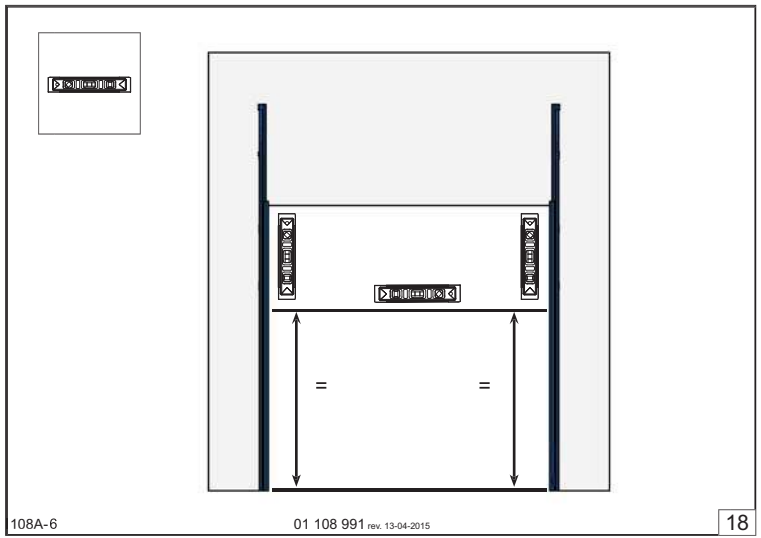
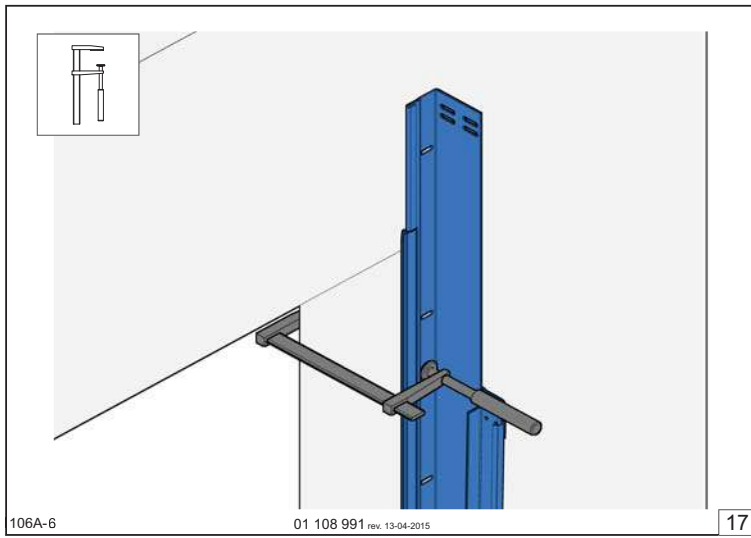

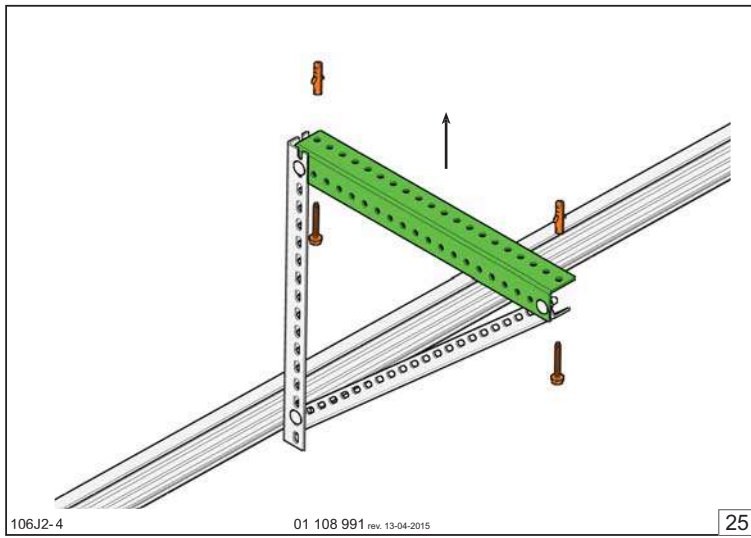

106J2-4

01 108 991 rev. 13-04-2015

25

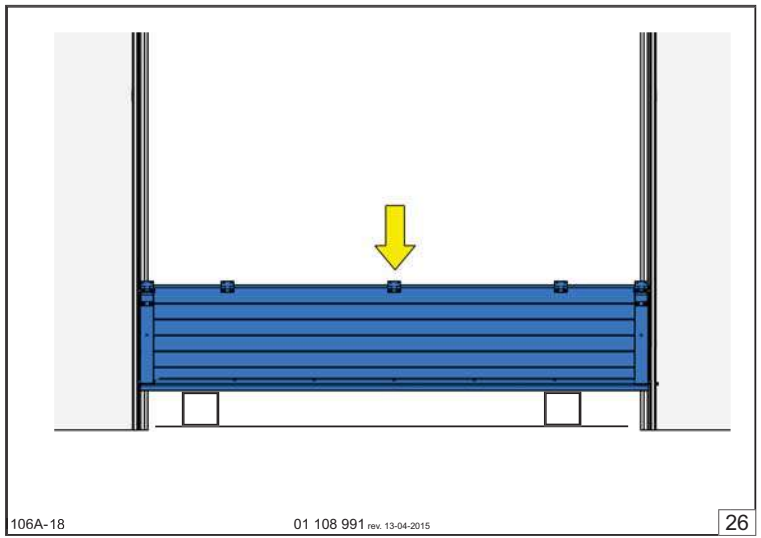

106A-18

01 108 991 rev. 13-04-2015

26

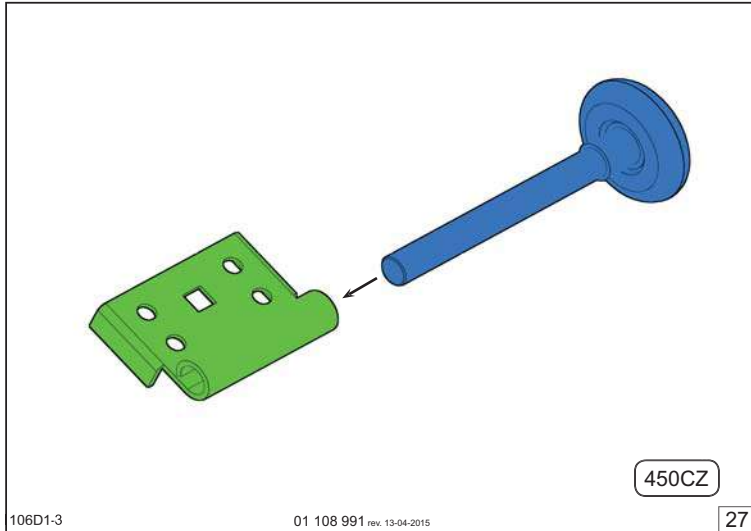

106D1-3

01 108 991 rev. 13-04-2015

27

450CZ

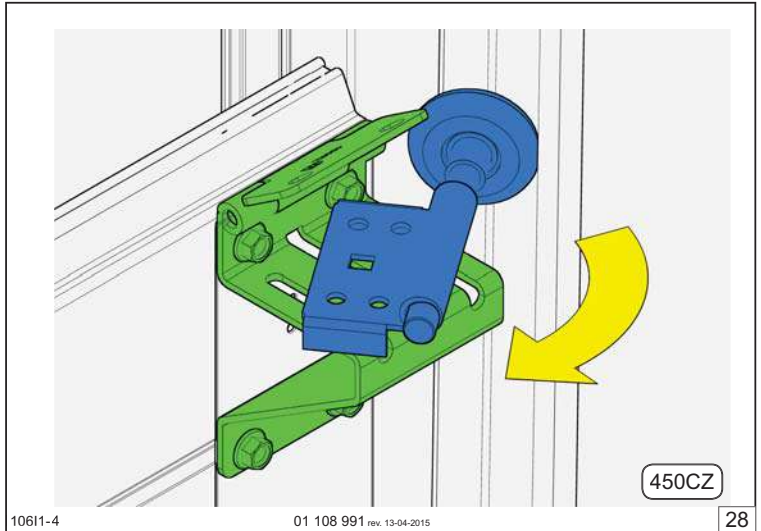

106I1-4

01 108 991 rev. 13-04-2015

28

450CZ

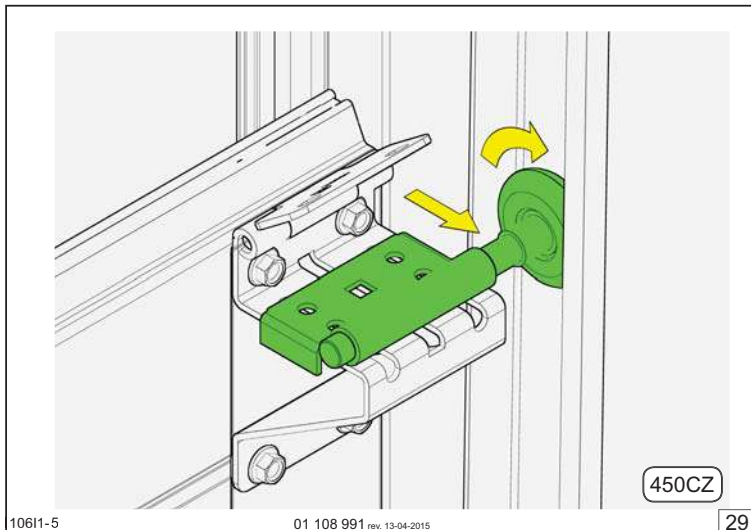

106I1-5

01 108 991 rev. 13-04-2015

29

450CZ

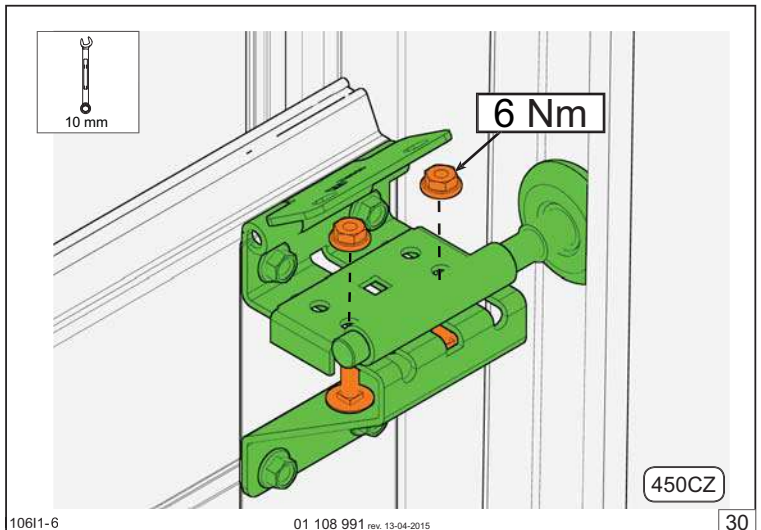

106I1-6

01 108 991 rev. 13-04-2015

30

10 mm

6 Nm

450CZ

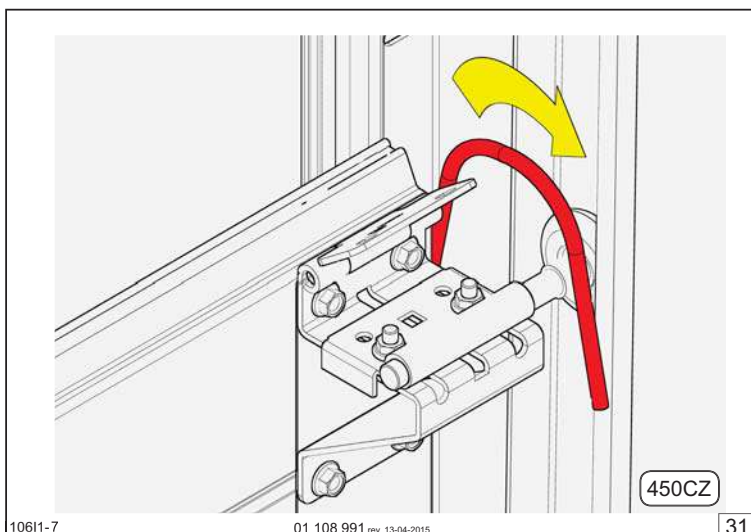

106I1-7

01 108 991 rev. 13-04-2015

31

450CZ

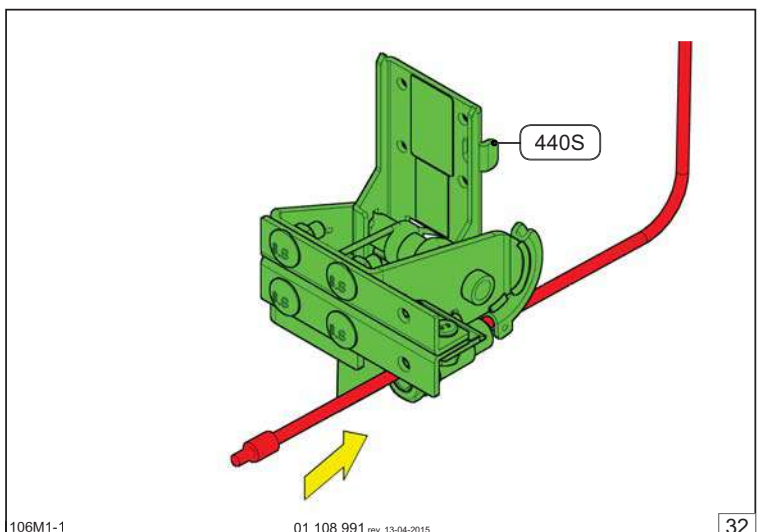

106M1-1

01 108 991 rev. 13-04-2015

32

440S

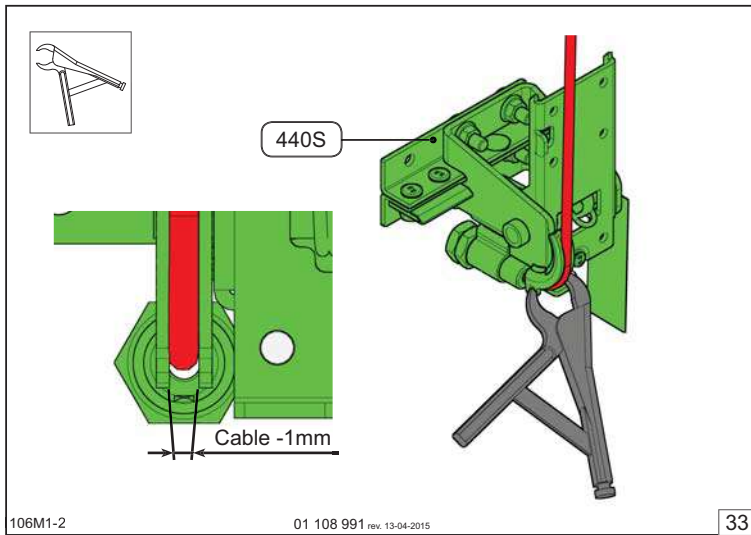

106M1-2

01 108 991 rev. 13-04-2015

33

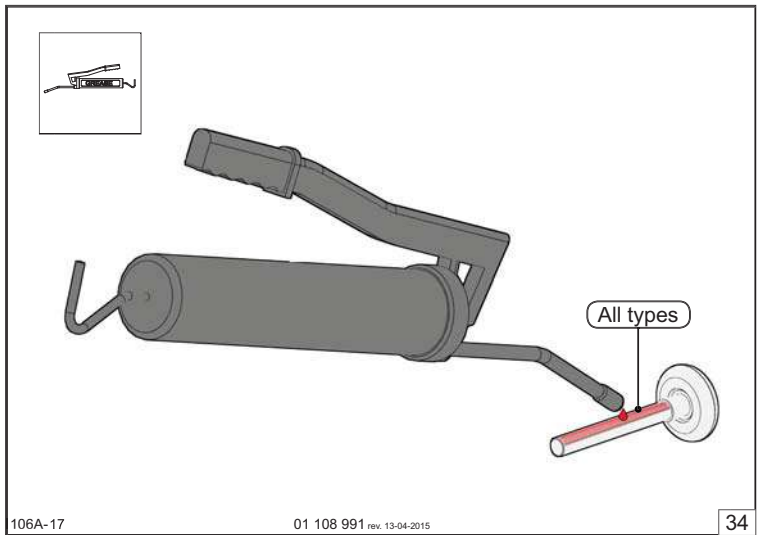

106A-17

01 108 991 rev. 13-04-2015

34

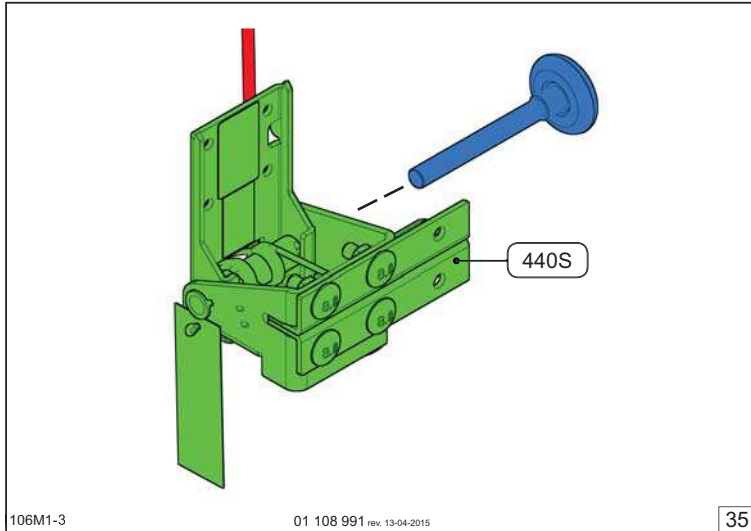

106M1-3

01 108 991 rev. 13-04-2015

35

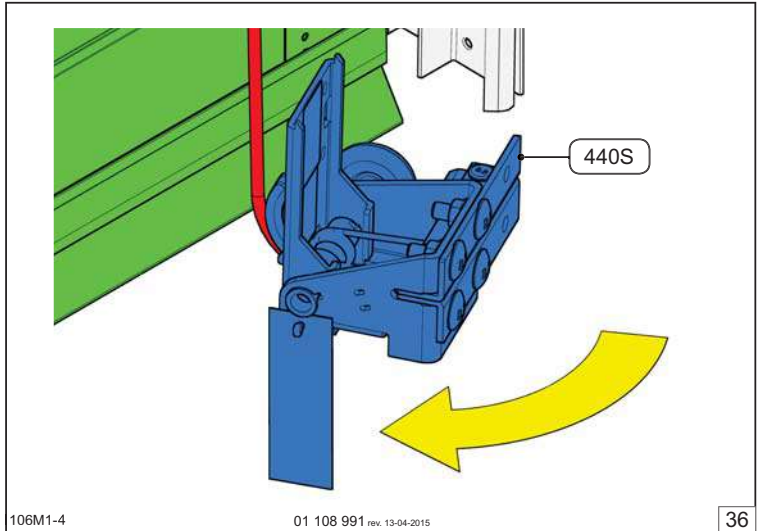

106M1-4

01 108 991 rev. 13-04-2015

36

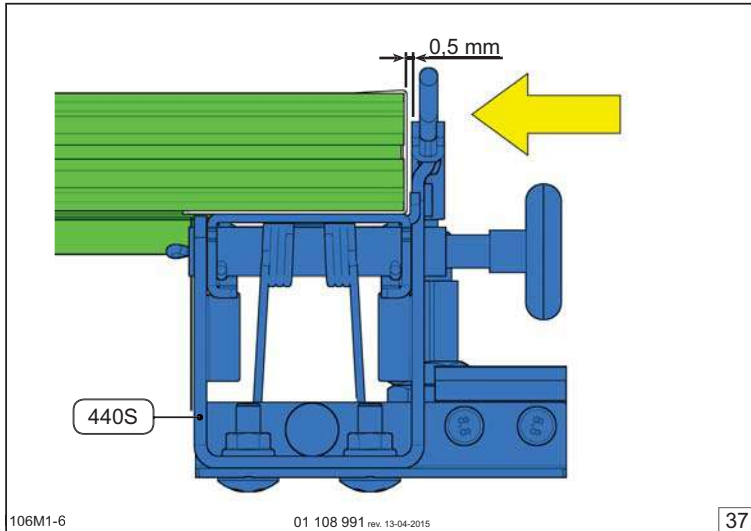

106M1-6

01 108 991 rev. 13-04-2015

37

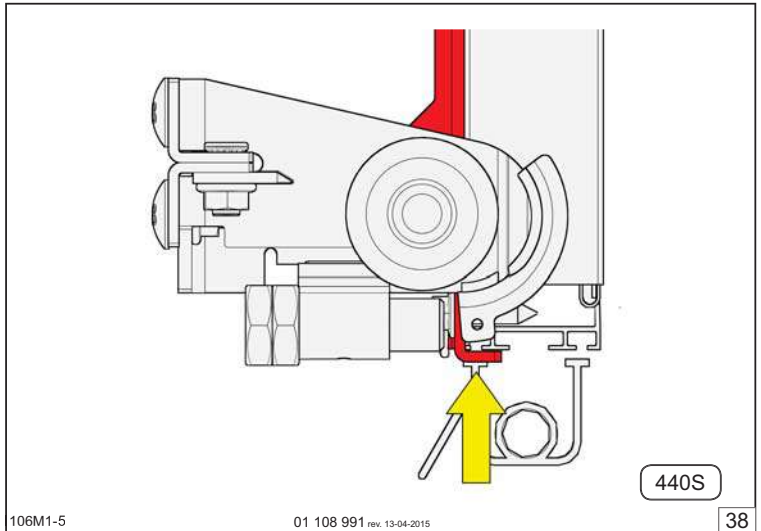

106M1-5

01 108 991 rev. 13-04-2015

38

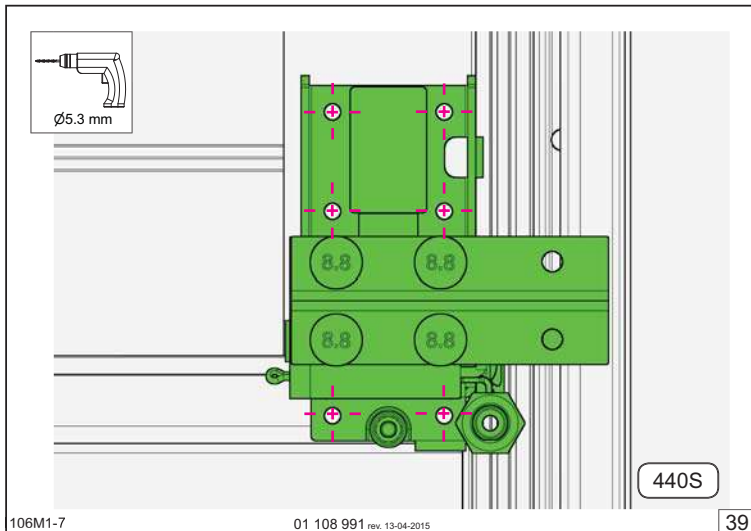

106M1-7

01 108 991 rev. 13-04-2015

39

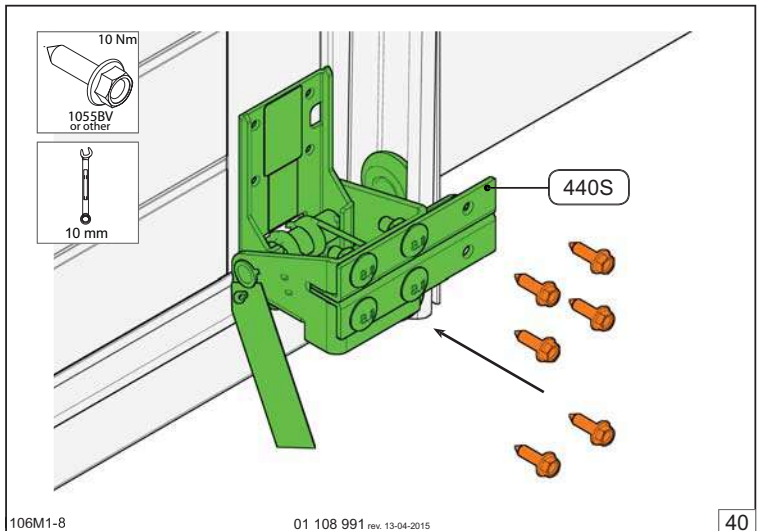

106M1-8

01 108 991 rev. 13-04-2015

40



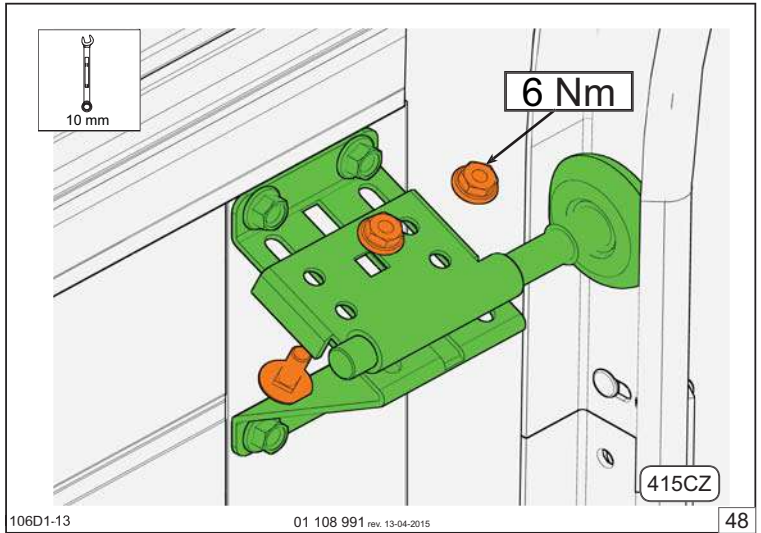
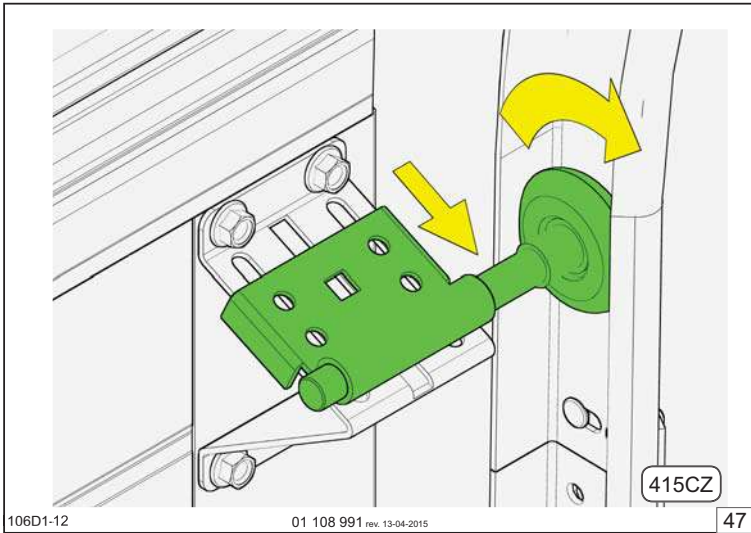
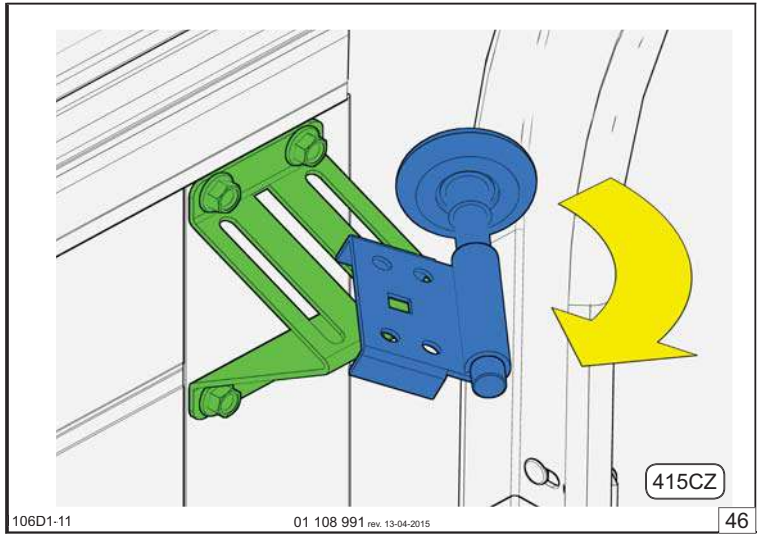
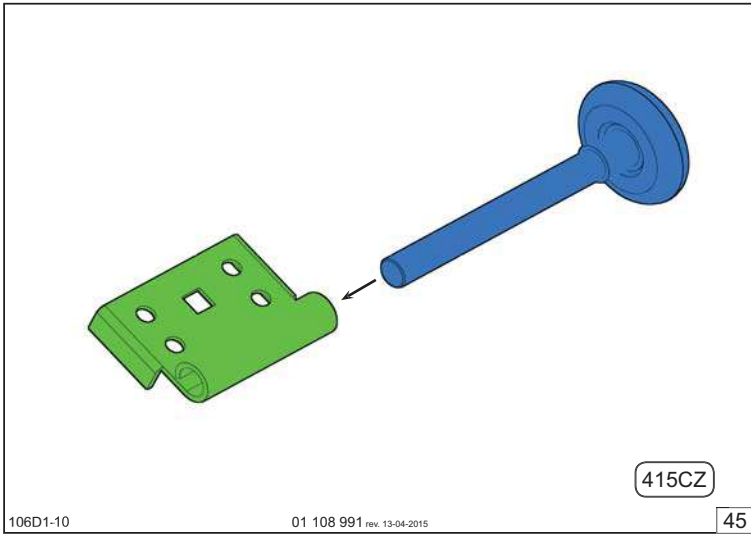
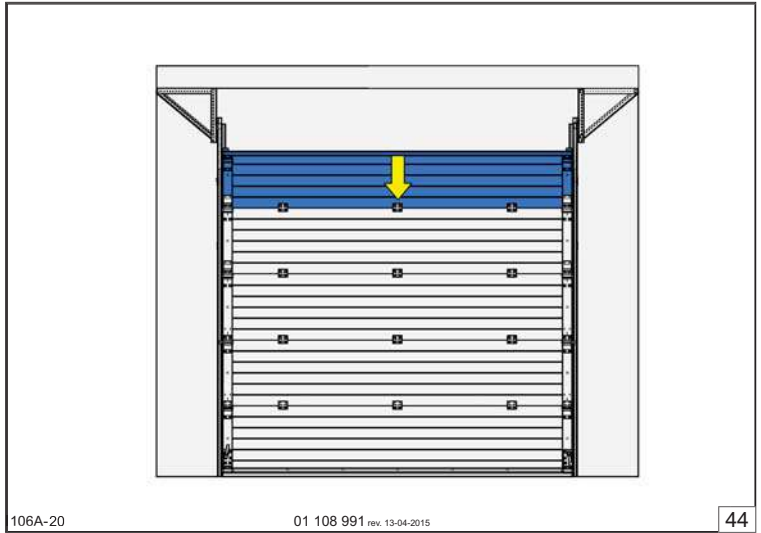
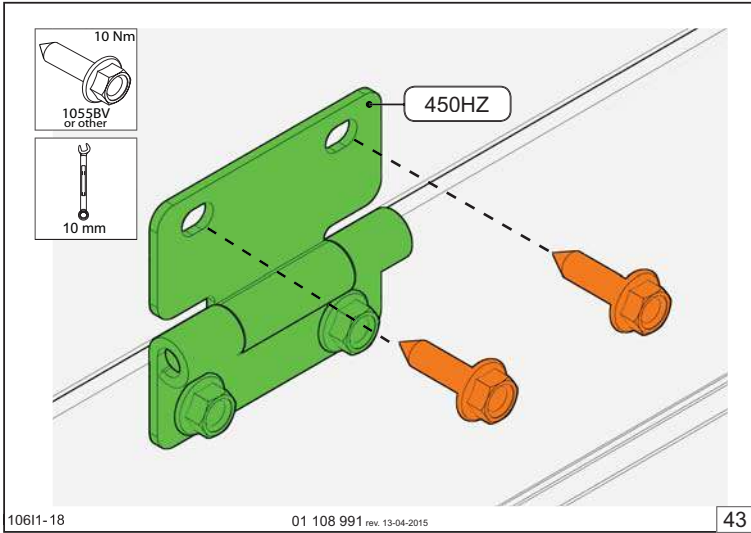
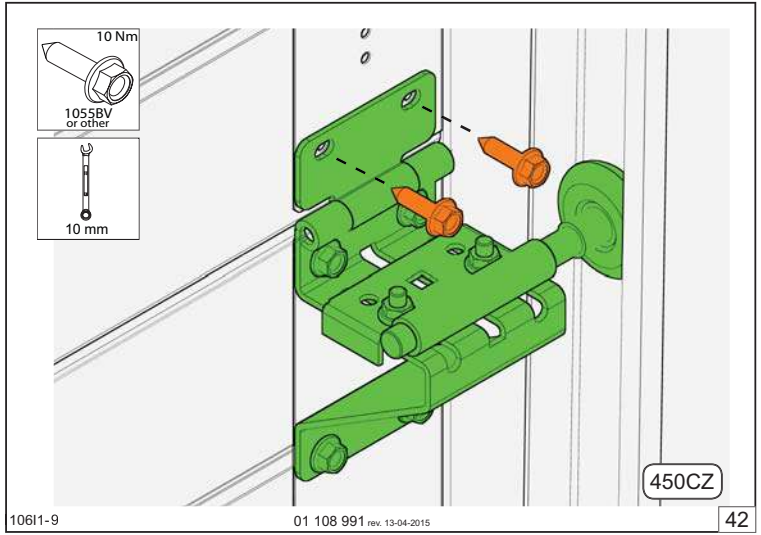
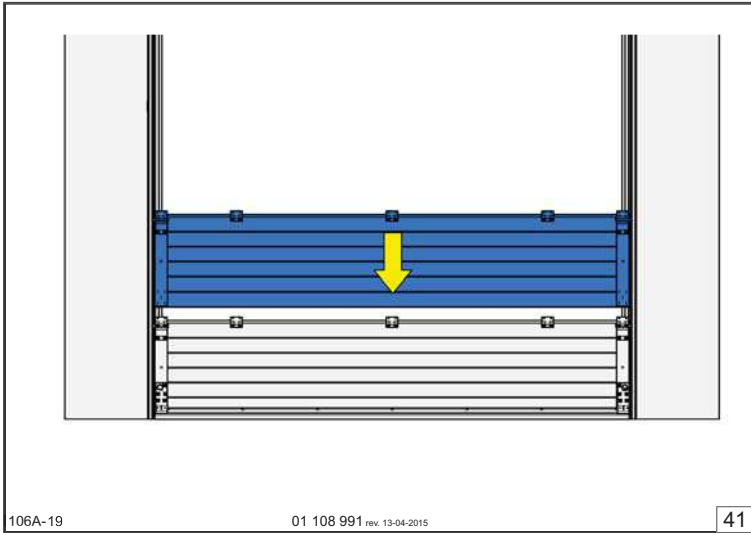

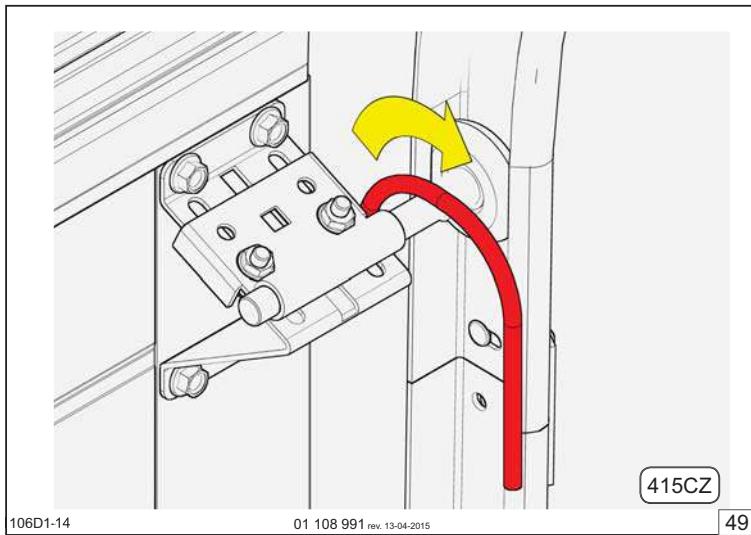

106D1-14

01 108 991 rev. 13-04-2015

49

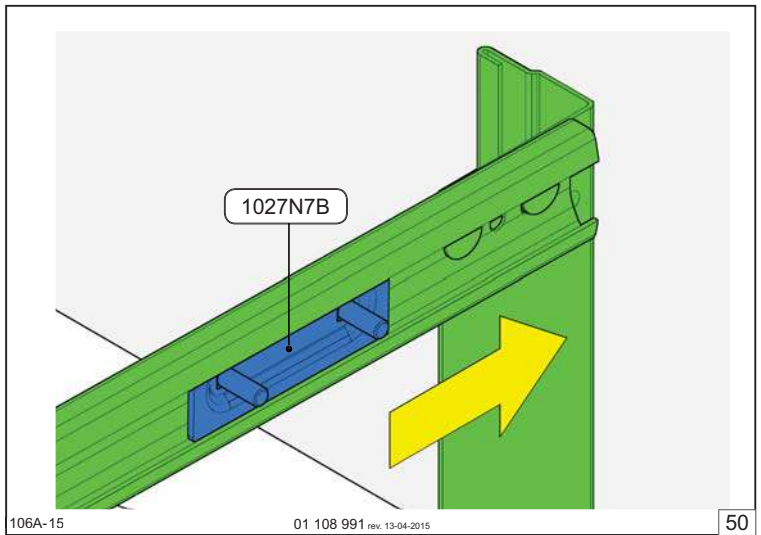

106A-15

01 108 991 rev. 13-04-2015

50

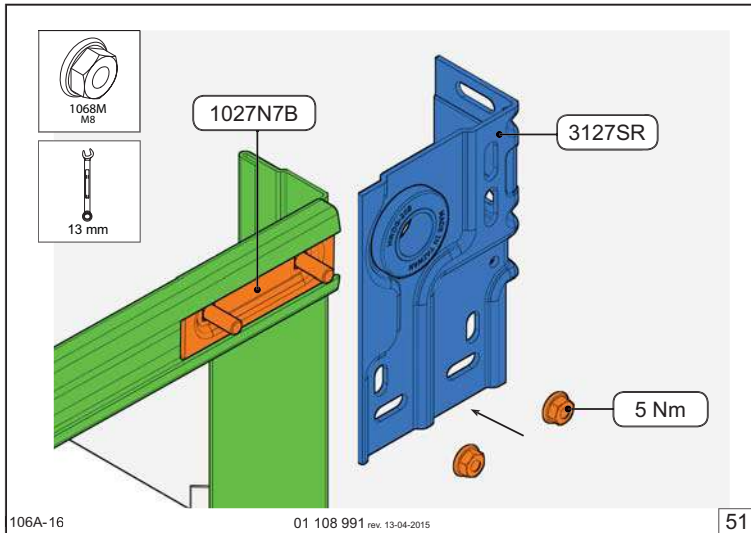

106A-16

01 108 991 rev. 13-04-2015

51

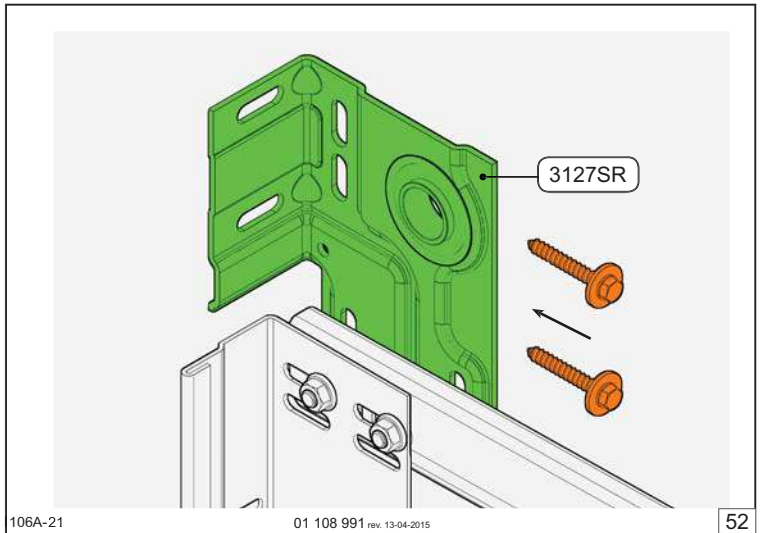

106A-21

01 108 991 rev. 13-04-2015

52

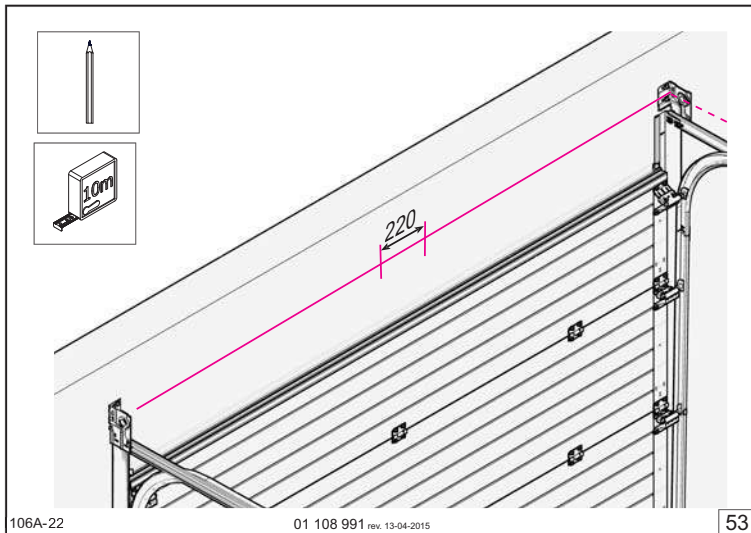

106A-22

01 108 991 rev. 13-04-2015

53

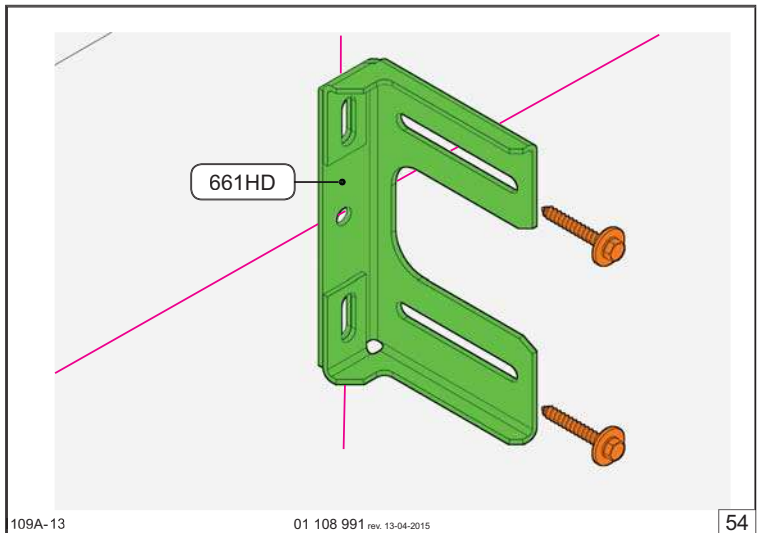

109A-13

01 108 991 rev. 13-04-2015

54

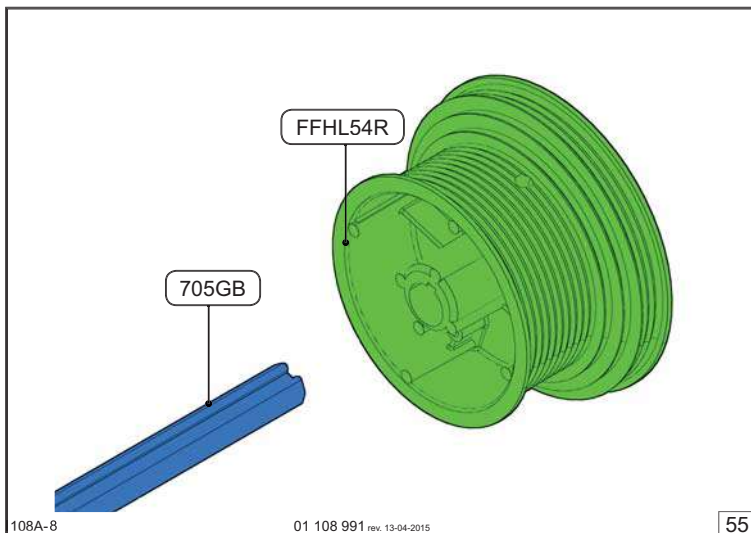

108A-8

01 108 991 rev. 13-04-2015

55

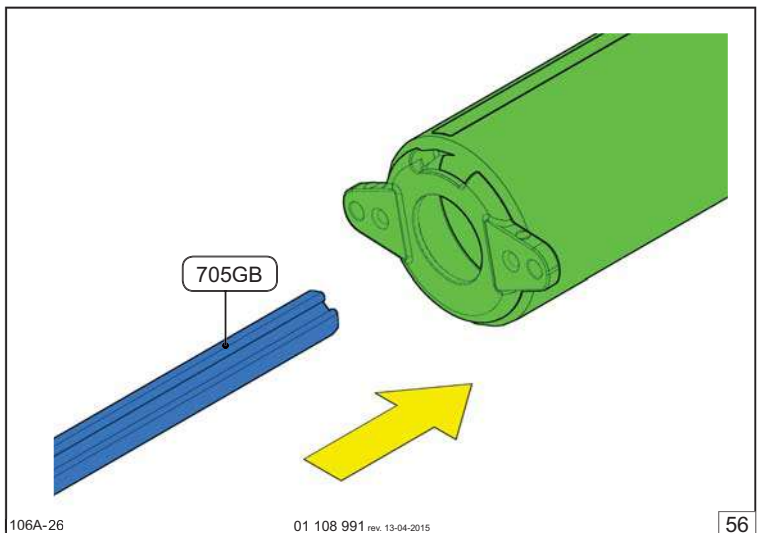

106A-26

01 108 991 rev. 13-04-2015

56



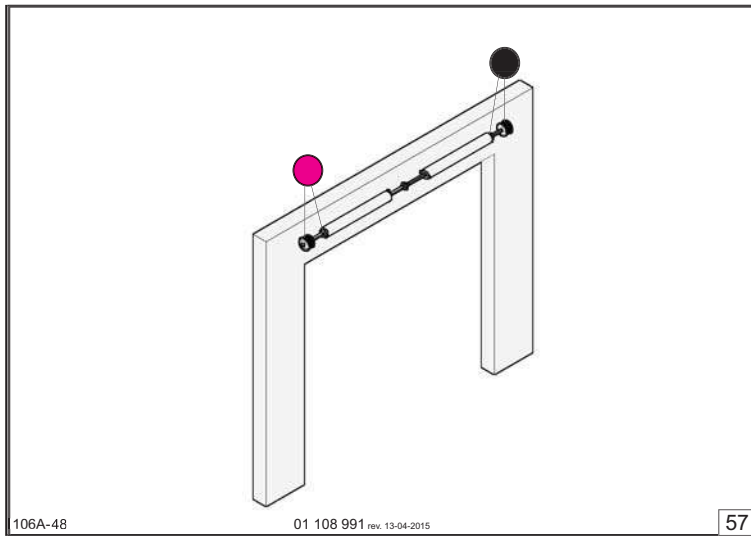

106A-48

01 108 991 rev. 13-04-2015

57

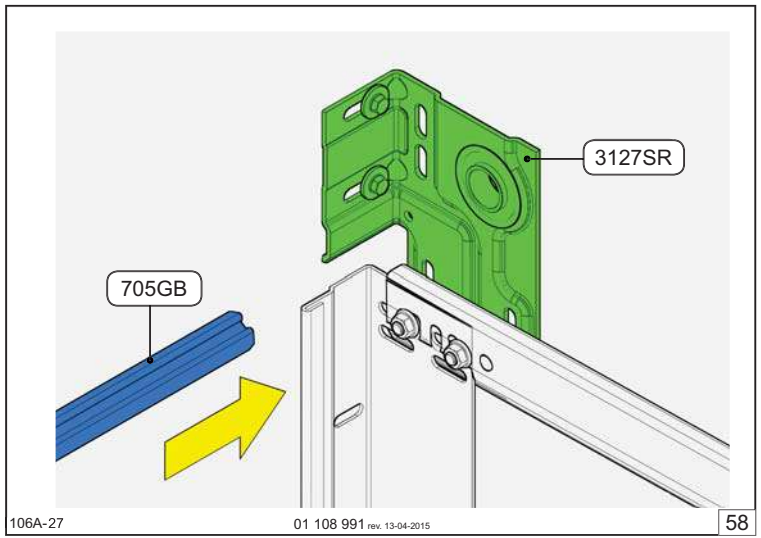

106A-27

01 108 991 rev. 13-04-2015

58

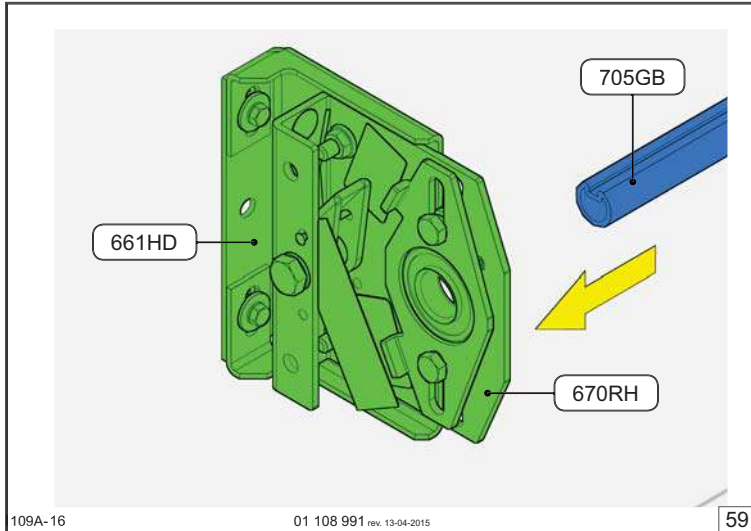

109A-16

01 108 991 rev. 13-04-2015

59

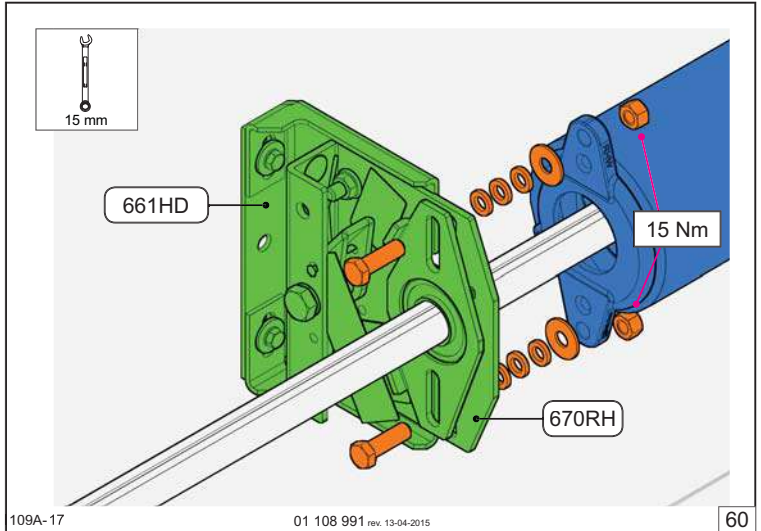

109A-17

01 108 991 rev. 13-04-2015

60

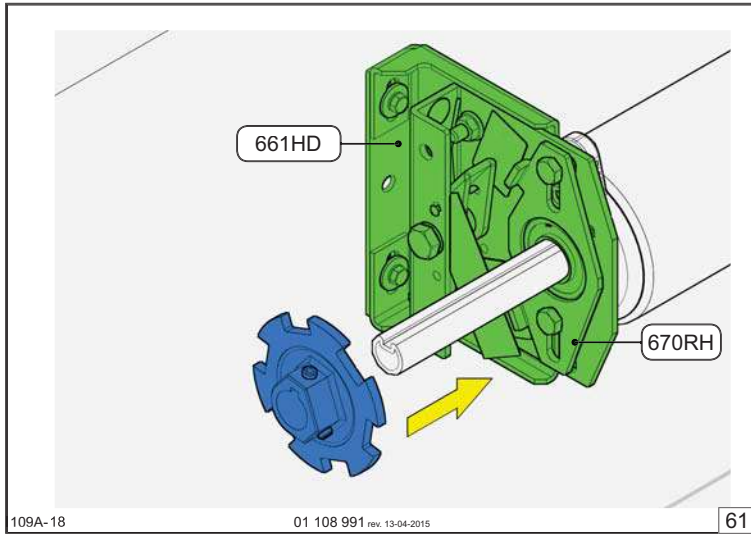

109A-18

01 108 991 rev. 13-04-2015

61

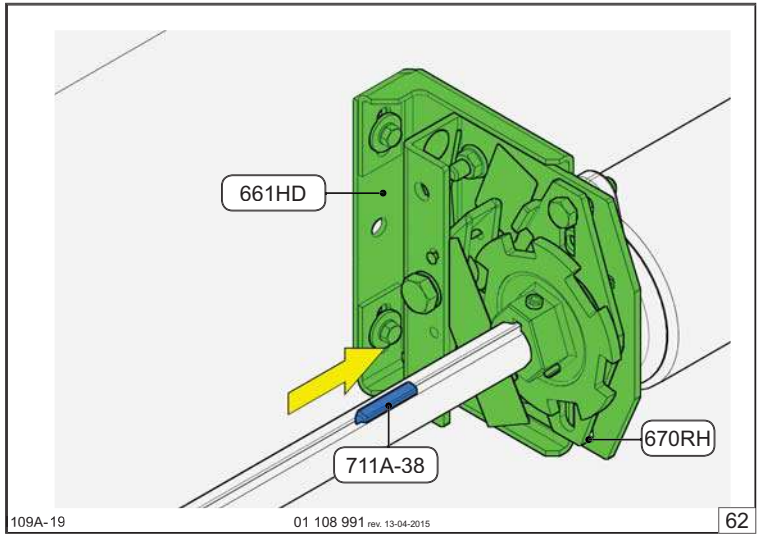

109A-19

01 108 991 rev. 13-04-2015

62

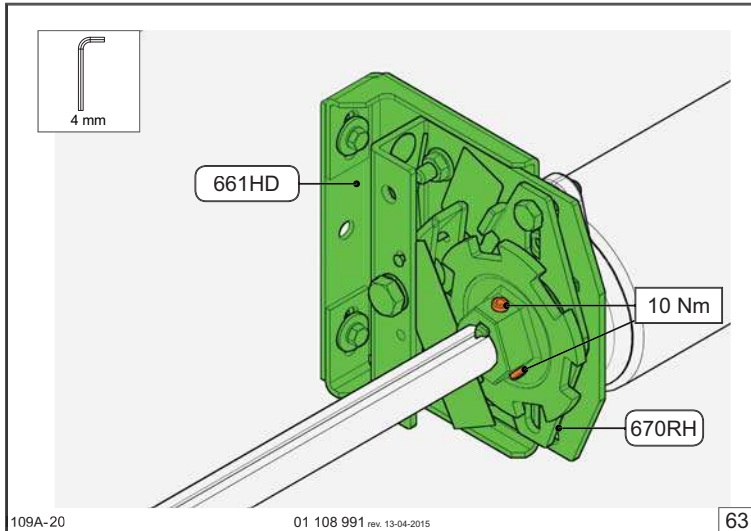

109A-20

01 108 991 rev. 13-04-2015

63

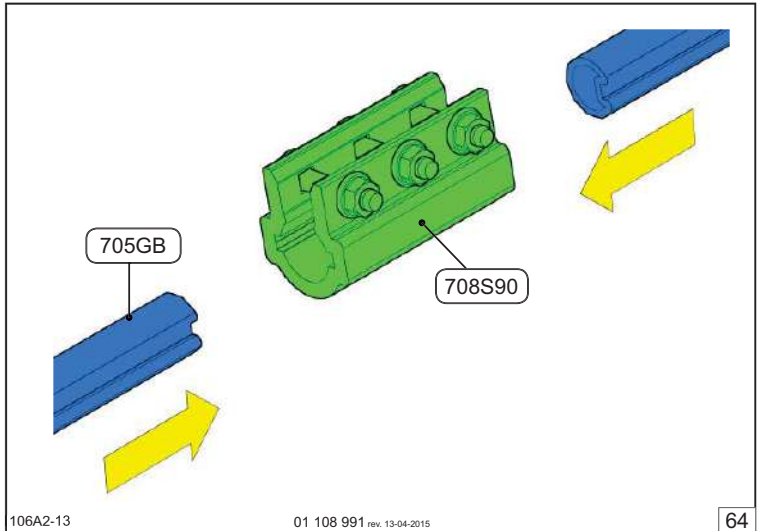

106A2-13

01 108 991 rev. 13-04-2015

64

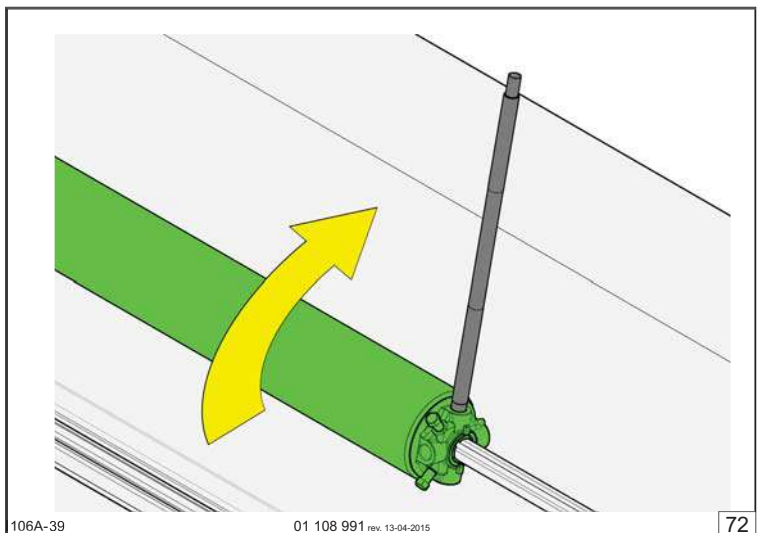
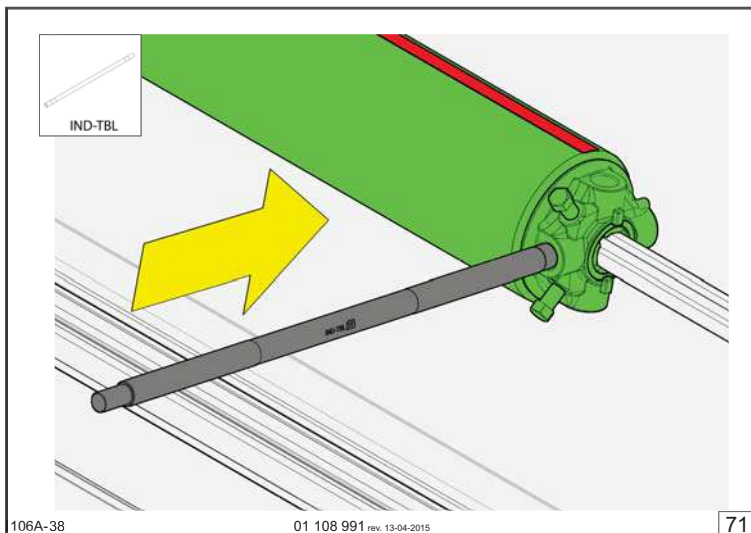
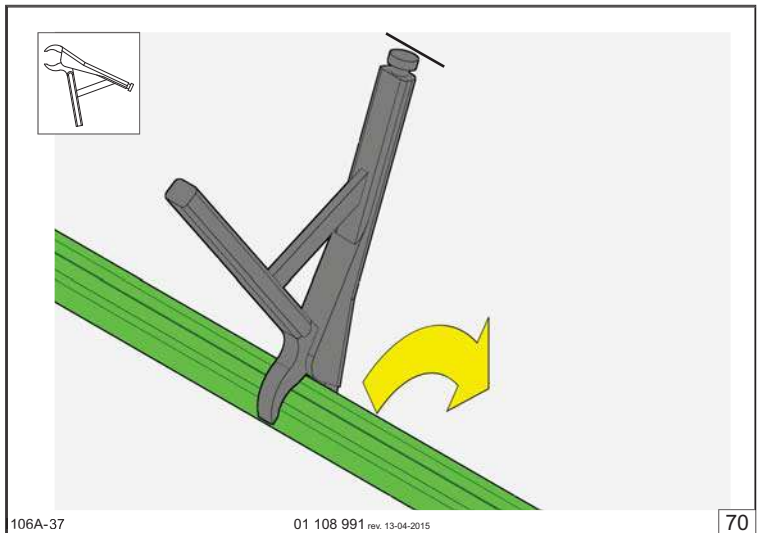
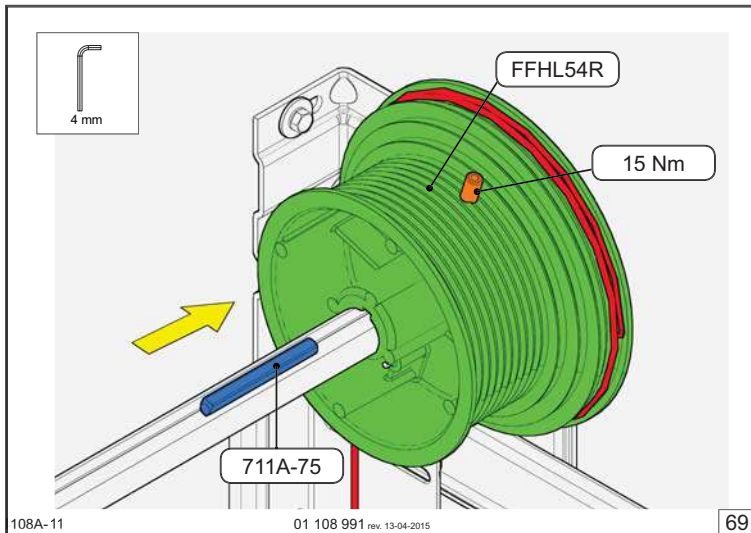
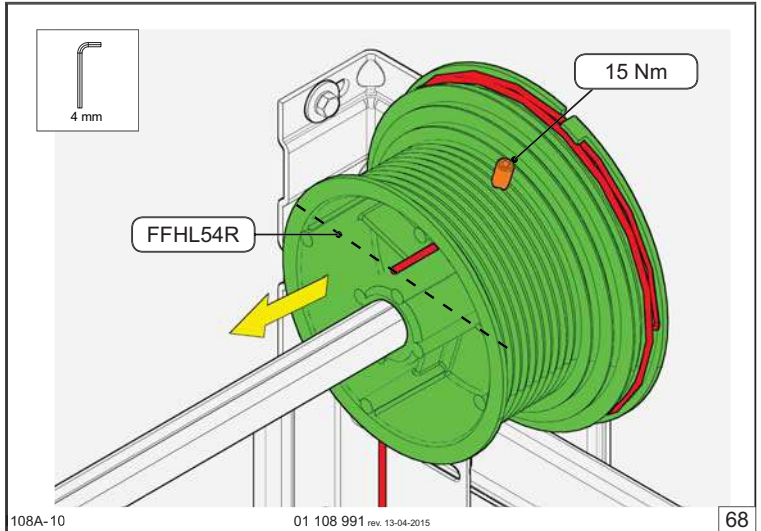
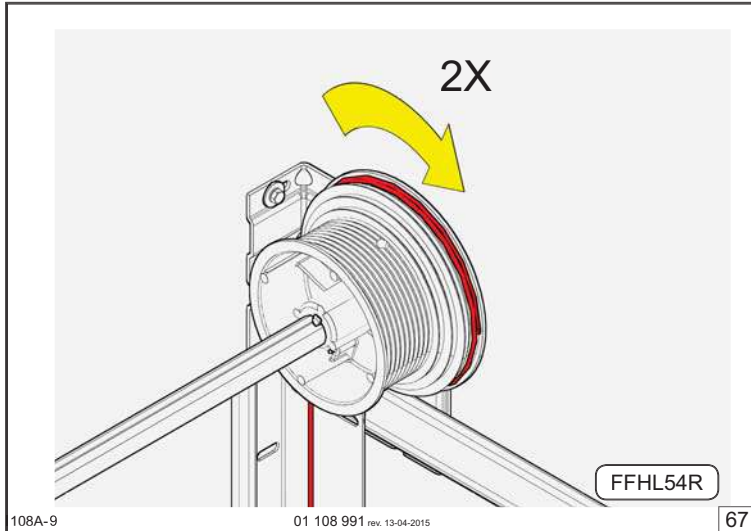
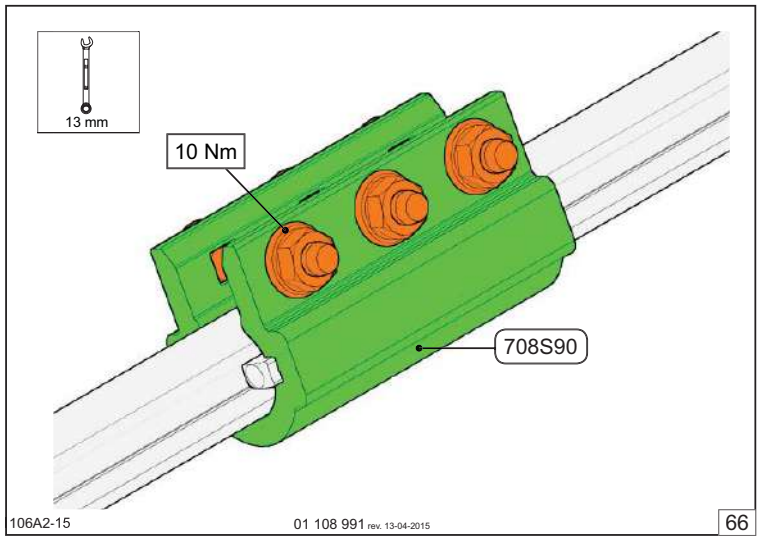
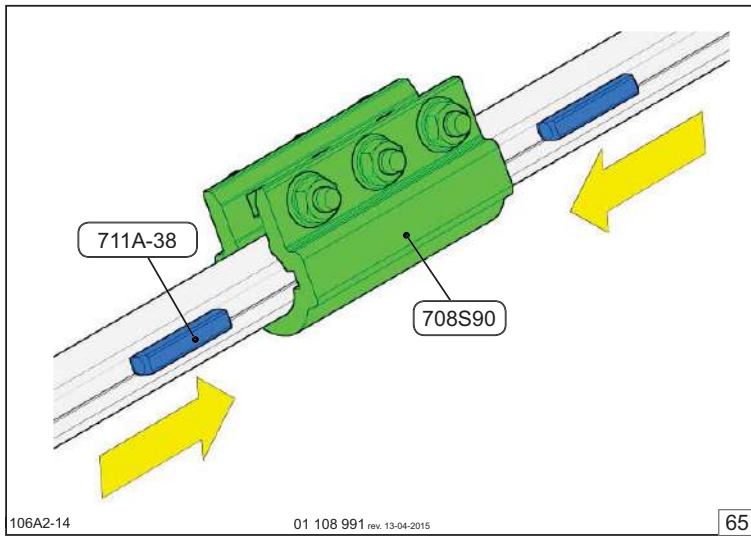





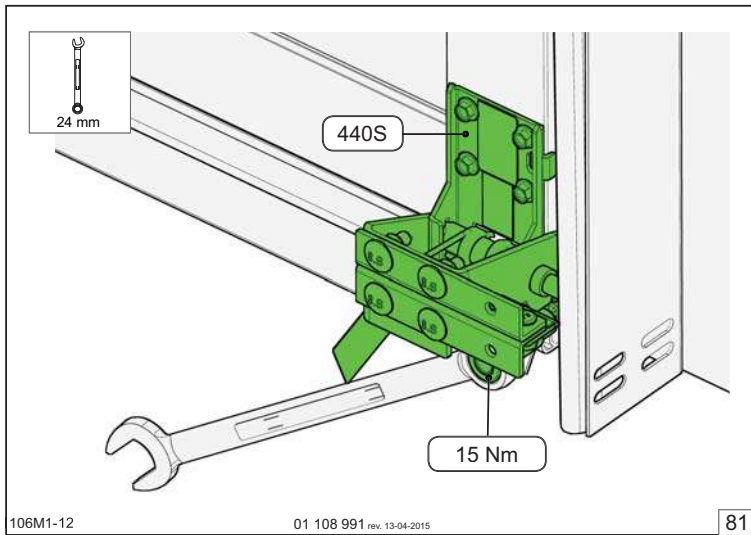

106M1-12

01 108 991 rev. 13-04-2015

81

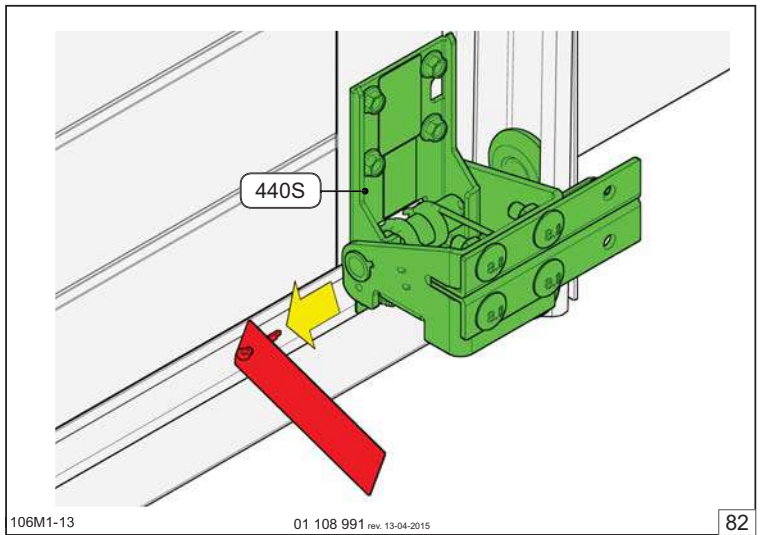

106M1-13

01 108 991 rev. 13-04-2015

82

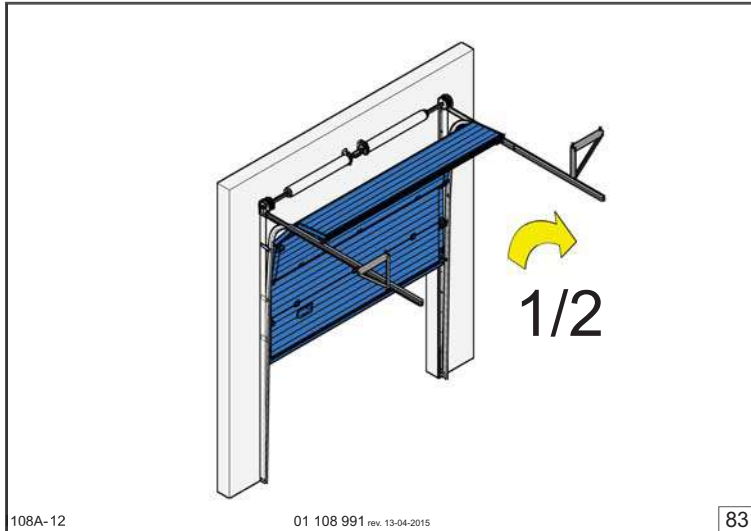

108A-12

01 108 991 rev. 13-04-2015

83

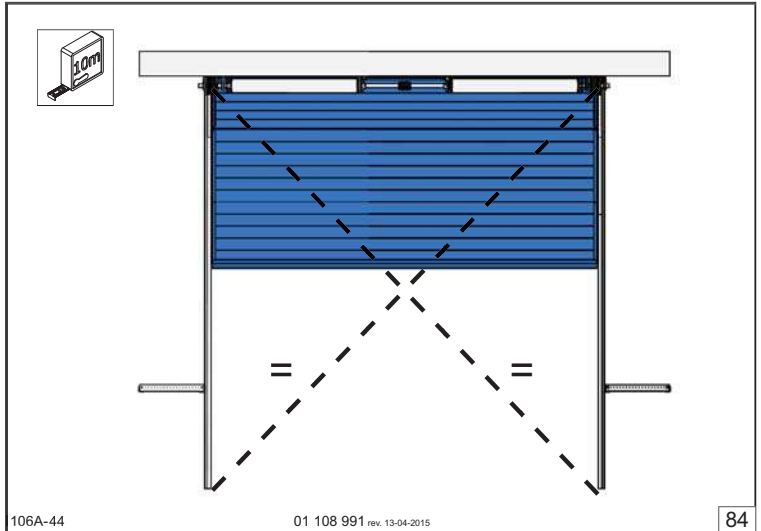

106A-44

01 108 991 rev. 13-04-2015

84

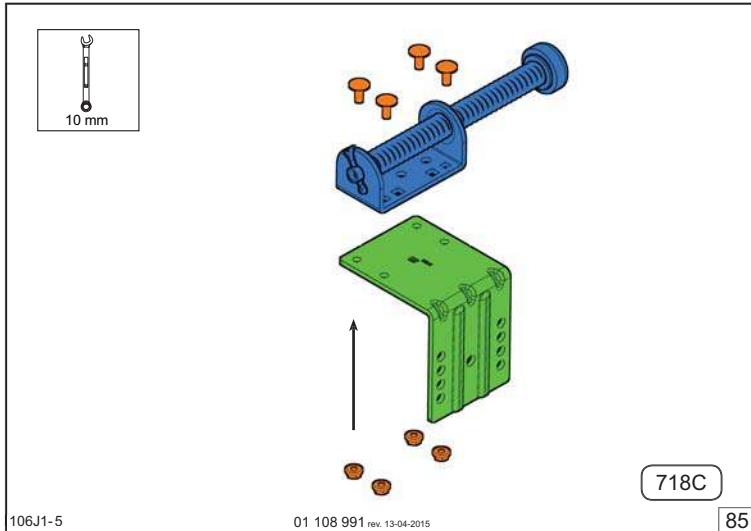

106J1-5

01 108 991 rev. 13-04-2015

85

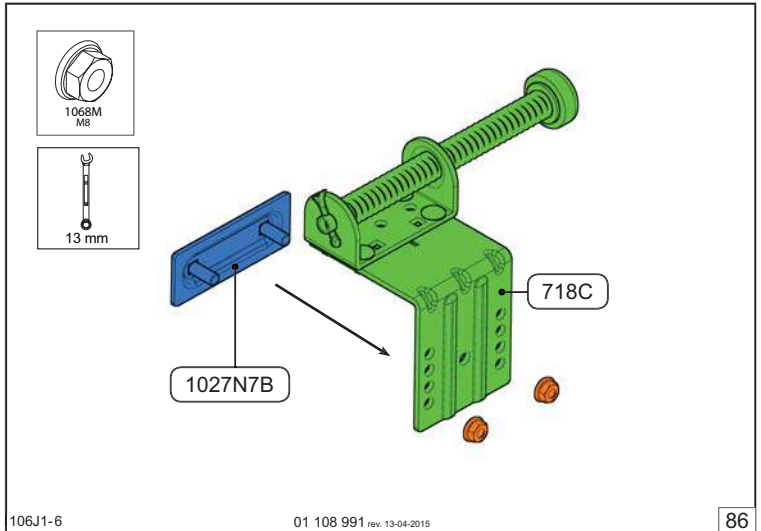

106J1-6

01 108 991 rev. 13-04-2015

86

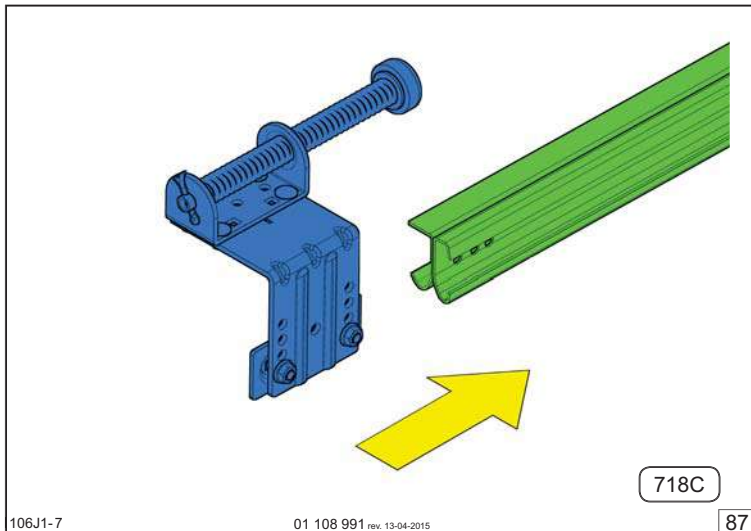

106J1-7

01 108 991 rev. 13-04-2015

87

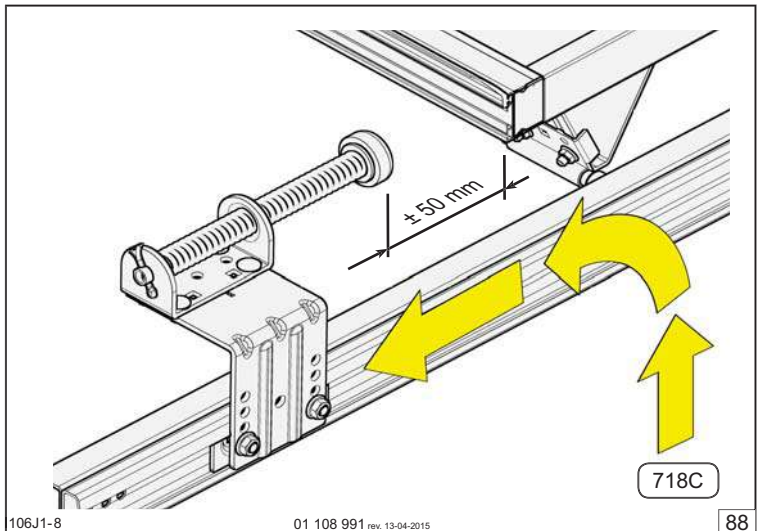

106J1-8

01 108 991 rev. 13-04-2015

88

